

 **FAC** per la natura
carta riciclata 100%

 **FAC** for nature
recycled paper 100%

 **FAC** pour la nature
papier recyclé 100%

 **FAC** ist umweltfreundlich
100% Altpapier

 **FAC** para la naturaleza
100% papel reciclado

 **FAC** voor de natuur
100% kringlooppapier

746ER & 780D

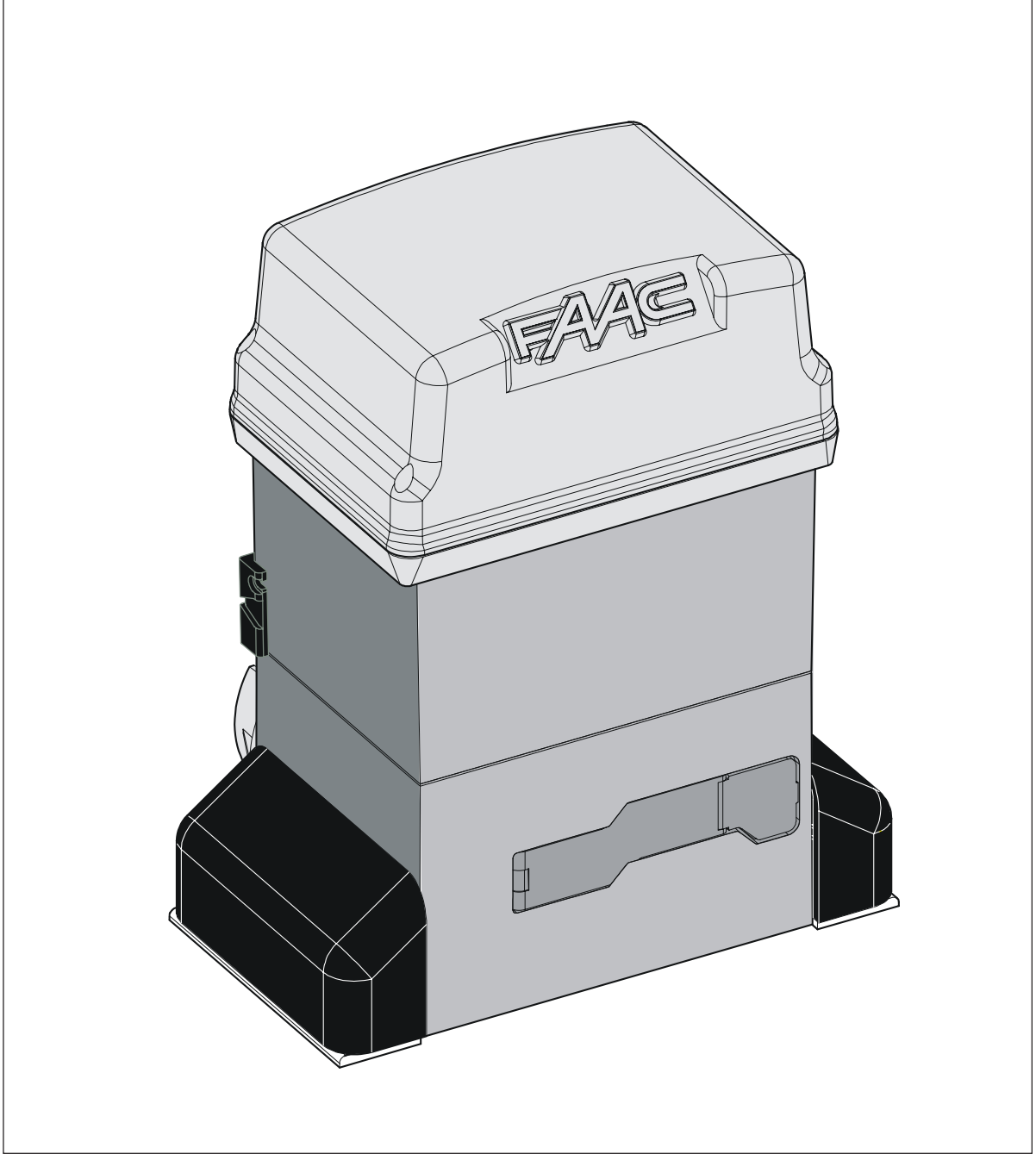

FAAC

EC DECLARATION OF CONFORMITY FOR MACHINES

(DIRECTIVE 98/37/EC)

Manufacturer: FAACS.p.A.

Address: Via Benini, 1 - 40069 Zola Predosa BOLOGNA - ITALY

Declares that: Operator mod. 746ER with electronic control unit 780D

- is built to be integrated into a machine or to be assembled with other machinery to create a machine under the provisions of Directive 98/37/EC;
- conforms to the essential safety requirements of the following EEC directives:

73/23/EEC and subsequent amendment 93/68/EEC,
89/336/EEC and subsequent amendment 92/31/EEC and 93/68/EEC

and also declares that it is prohibited to put into service the machinery until the machine in which it will be integrated or of which it will become a component has been identified and declared as conforming to the conditions of Directive 98/37/EC.

Bologna, 01 January 2004

The Managing Director
A. Bassi



WARNINGS FOR THE INSTALLER

GENERAL SAFETY OBLIGATIONS

- 1) **ATTENTION! To ensure the safety of people, it is important that you read all the following instructions. Incorrect installation or incorrect use of the product could cause serious harm to people.**
- 2) Carefully read the instructions before beginning to install the product.
- 3) Do not leave packing materials (plastic, polystyrene, etc.) within reach of children as such materials are potential sources of danger.
- 4) Store these instructions for future reference.
- 5) This product was designed and built strictly for the use indicated in this documentation. Any other use, not expressly indicated here, could compromise the good condition/operation of the product and/or be a source of danger.
- 6) FAAC declines all liability caused by improper use or use other than that for which the automated system was intended.
- 7) Do not install the equipment in an explosive atmosphere: the presence of inflammable gas or fumes is a serious danger to safety.
- 8) The mechanical parts must conform to the provisions of Standards EN 12604 and EN 12605.
For non-EU countries, to obtain an adequate level of safety, the Standards mentioned above must be observed, in addition to national legal regulations.
- 9) FAAC is not responsible for failure to observe Good Technique in the construction of the closing elements to be motorised, or for any deformation that may occur during use.
- 10) The installation must conform to Standards EN 12453 and EN 12445.
For non-EU countries, to obtain an adequate level of safety, the Standards mentioned above must be observed, in addition to national legal regulations.
- 11) Before attempting any job on the system, cut out electrical power .
- 12) The mains power supply of the automated system must be fitted with an all-pole switch with contact opening distance of 3mm or greater. Use of a 6A thermal breaker with all-pole circuit break is recommended.
- 13) Make sure that a differential switch with threshold of 0.03 A is fitted upstream of the system.
- 14) Make sure that the earthing system is perfectly constructed, and connect metal parts of the means of the closure to it.
- 15) The automated system is supplied with an intrinsic anti-crushing safety device consisting of a torque control. Nevertheless, its tripping threshold must be checked as specified in the Standards indicated at point 10.
- 16) The safety devices (EN 12978 standard) protect any danger areas against **mechanical movement Risks**, such as crushing, dragging, and shearing.
- 17) Use of at least one indicator-light (e.g. FAACLIGHT) is recommended for every system, as well as a warning sign adequately secured to the frame structure, in addition to the devices mentioned at point "16".
- 18) FAAC declines all liability as concerns safety and efficient operation of the automated system, if system components not produced by FAAC are used.
- 19) For maintenance, strictly use original parts by FAAC.
- 20) Do not in any way modify the components of the automated system.
- 21) The installer shall supply all information concerning manual operation of the system in case of an emergency, and shall hand over to the user the warnings handbook supplied with the product.
- 22) Do not allow children or adults to stay near the product while it is operating.
- 23) Keep remote controls or other pulse generators away from children, to prevent the automated system from being activated involuntarily.
- 24) Transit is permitted only when the automated system is idle.
- 25) The user must not attempt any kind of repair or direct action whatever and contact qualified personnel only.
- 26) Maintenance: check at least every 6 months the efficiency of the system, particularly the efficiency of the safety devices (including, where foreseen, the operator thrust force) and of the release devices.
- 27) **Anything not expressly specified in these instructions is not permitted.**

AUTOMATED SYSTEM 746 & ELECTRONIC CONTROL UNIT 780D

These instructions apply to the following models:

746 ER Z16 - 746 ER Z20 - 746 ER CAT - 746 ER RF

The FAAC mod. 746 automated system for sliding gates is an electro-mechanical operator transmitting motion to the sliding leaf via a rack or chain pinion appropriately coupled to the gate.

The non-reversing system ensures the gate is mechanically locked when the motor is not operating and, therefore, no lock needs to be installed.

The gearmotor is equipped with a mechanical clutch which, combined with an electronic device, offers the necessary adjustable anti-crushing safety and guarantees stopping or reversing the gate movement. A handy manual release makes it possible to move the gate in the event of a power cut or malfunction. The electronic control equipment is equipped with a gearmotor and is housed inside the operator.

The 746 automated system was designed and manufactured to control access of vehicles. Avoid any other use whatever.

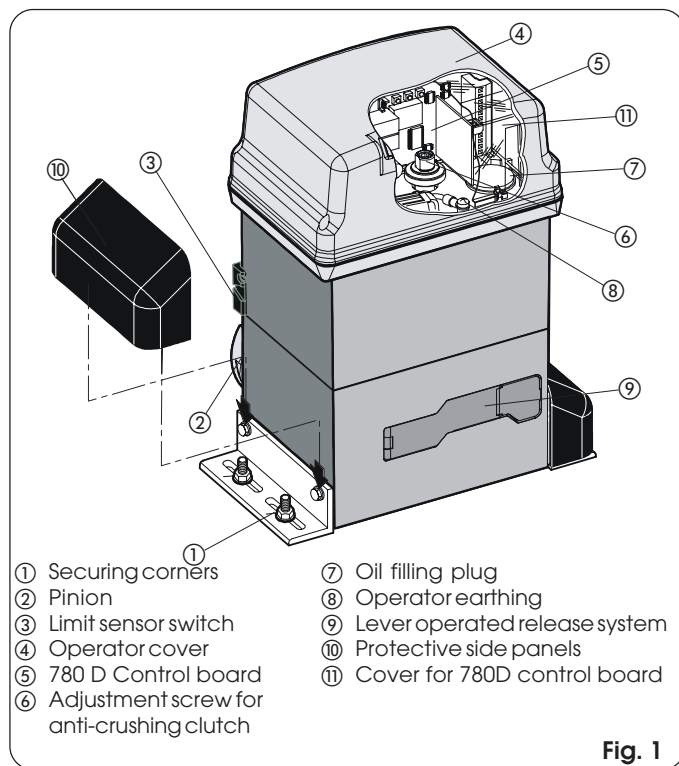

- | | |
|---|---------------------------------|
| ① Securing corners | ⑦ Oil filling plug |
| ② Pinion | ⑧ Operator earthing |
| ③ Limit sensor switch | ⑨ Lever operated release system |
| ④ Operator cover | ⑩ Protective side panels |
| ⑤ 780 D Control board | ⑪ Cover for 780D control board |
| ⑥ Adjustment screw for anti-crushing clutch | |

Fig. 1

1. DESCRIPTION AND TECHNICAL SPECIFICATIONS

1.1. MAXIMUM USE CURVE

The curve makes it possible to establish maximum work time (T) according to use frequency (F).

E.g.: The 746 gearmotor can operate non-stop at 70% use frequency.

To ensure efficient operation, operate in the work range below the curve.

Important: The curve is obtained at a temperature of 24°C. Exposure to the direct sun rays can reduce use frequency down to 20%.

Calculation of use frequency

The percentage of effective work time (opening + closing) compared to total time of cycle (opening + closing + pause times).

Calculation formula:

$$\%F = \frac{T_a + T_c}{T_a + T_c + T_p + T_i} \times 100$$

where:

T_a = opening time

T_c = closing time

T_p = pause time

T_i = time of interval between two complete cycles

Use frequency graph

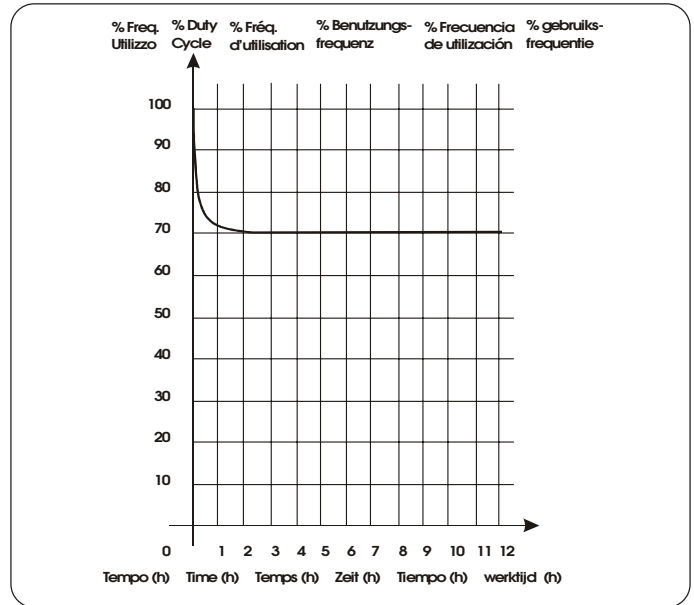

Tab. 1 TECHNICAL SPECIFICATIONS OF 746 GEARMOTOR

MODEL	746
Power supply (Vac +6% -10% 50-60Hz)	230
Absorbed power (W)	300
Reduction ratio	1 : 30
Type of pinion	Z20-Z16
Rack	Module 4-step 12.566
Max. thrust (daN)	50 (Z20) - 62,5 (Z16)
Max. Torque (Nm)	20
Winding thermal protection (°C)	120
Use frequency	70% (see graph)
Oil quantity (l)	1,8
Type of oil	FAACXD220
Operative ambient temperature (°C)	-20 ÷ +55
Gearmotor weight (Kg)	14
Protection class	IP 44
Gate max. weight (Kg)	400 (Z20) - 600 (Z16)
Gate speed (m/min)	12 (Z20) - 9,6 (Z16)
Gate max. length (m) (time-out)	50 (Z20) - 40 (Z16)
Clutch	twin-disk in oil bath
Protective treatment	cataphoresis
Equipment	780D
Limit-switch	MSL or inductive
Gearmotor overall dimensions LxHxD (mm)	see Fig. 2
Electric motor technical specifications	
RPM	1400
Power (W)	300
Absorbed current (A)	1.5
Starting capacitor (µF)	25
Power supply (Vac +6% -10%; 50-60Hz)	230

2. DIMENSIONS

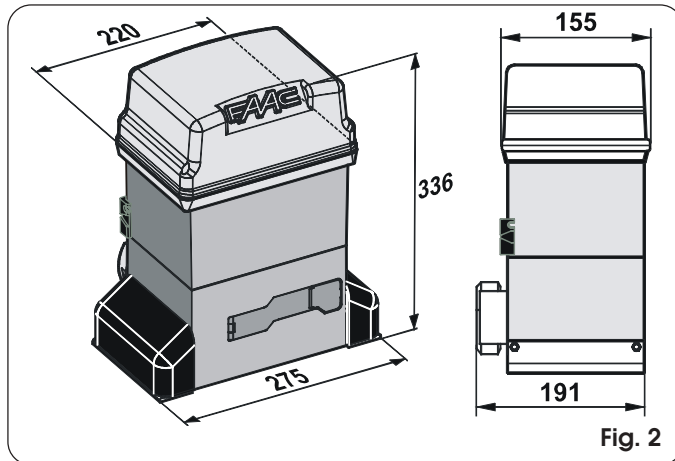

Fig. 2

3. ELECTRIC EQUIPMENT (standard system)

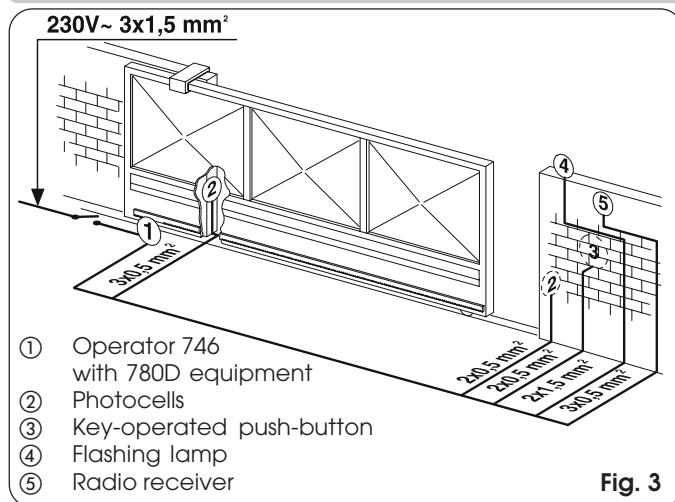

Fig. 3

4. INSTALLATION OF THE AUTOMATED SYSTEM

4.1. PRELIMINARY CHECKS

To ensure safety and an efficiently operating automated system, make sure the following conditions are observed:

- The gate structure must be suitable for automation. The following are necessary in particular: wheel diameter must be in proportion to the weight of the gate to be automated, an upper guide must be provided, plus mechanical stop limits to prevent the gate derailing.
- The soil must permit sufficient stability for the foundation plinth.
- There must be no pipes or electric cables in the plinth excavation area.
- If the gearmotor is exposed to passing vehicles, install, if possible, adequate means of protection against accidental impact.
- Check if an efficient earthing is available for connection to the gearmotor.

4.2. MASONRY FOR FOUNDATION PLATE

- 1) Assemble the foundation plate as shown in figure 4.
- 2) The foundation plate must be located as shown in figure 5 (right closing) or figure 6 (left closing) to ensure the rack and pinion mesh correctly.
- 3) Prepare a foundation plinth as shown in fig.7 and wall the foundation plate, supplying one or more sheaths for routing electric cables. Using a spirit level, check if the plate is perfectly level. Wait for the cement to set.
- 4) Lay the electric cables for connection to the accessories and power supply as shown in figure 3.

To make the connections efficiently, allow the cables to project by about 40 cm from the hole (Figs.5-6 ref. 1) of the foundation plate.

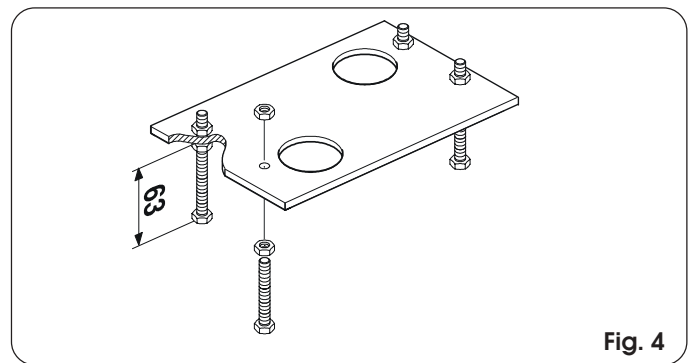

Fig. 4

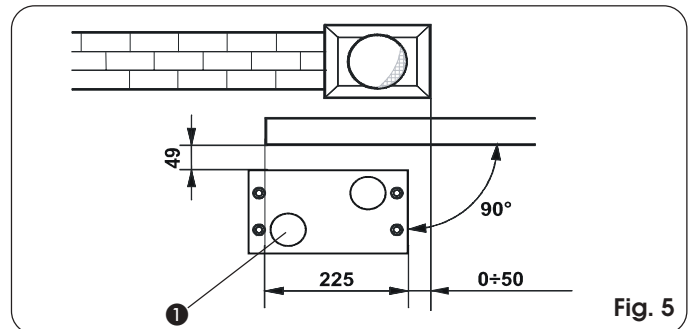

Fig. 5

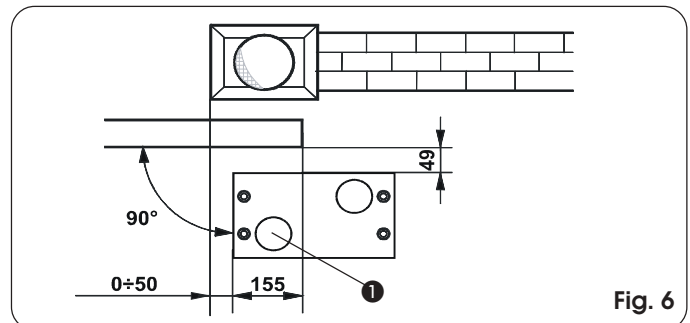

Fig. 6

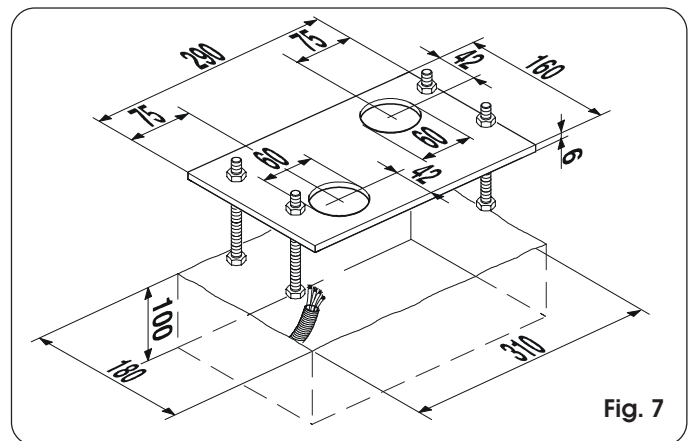

Fig. 7

4.3. MECHANICAL INSTALLATION

- 1) Assemble the securing corners and anti-vibration spacers on the operator as shown in Fig. 8.
- 2) Open the cover, unscrewing the securing screws.
- 3) Place the operator on the plate, using the supplied washers and nuts as shown in Fig. 9.

During this operation, route the cables through the duct inside the lower half-casing of the operator (Fig. 10 - Ref. A). To access the electronic equipment, route the cables through the appropriate hole, using the supplied rubber cable-clamp. Make absolutely sure to unsheath all the cables so that the clamp holds single cables only (Fig. 10 - Ref. B).

- 5) Secure the gearmotor to the foundation plate, tightening the nuts as in Fig. 12.
- 6) Prepare the operator for manual operating mode as described in chapter 8.

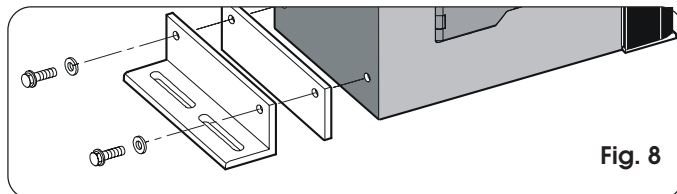

Fig. 8

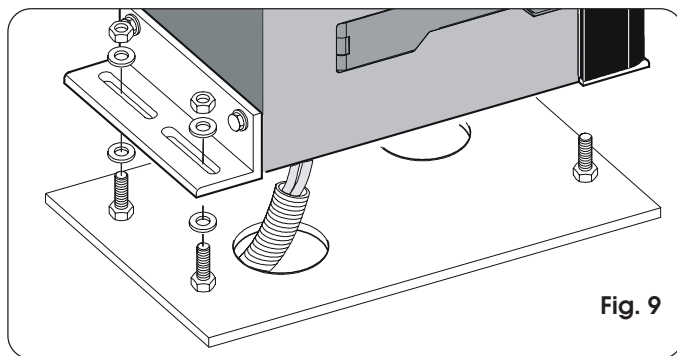

Fig. 9

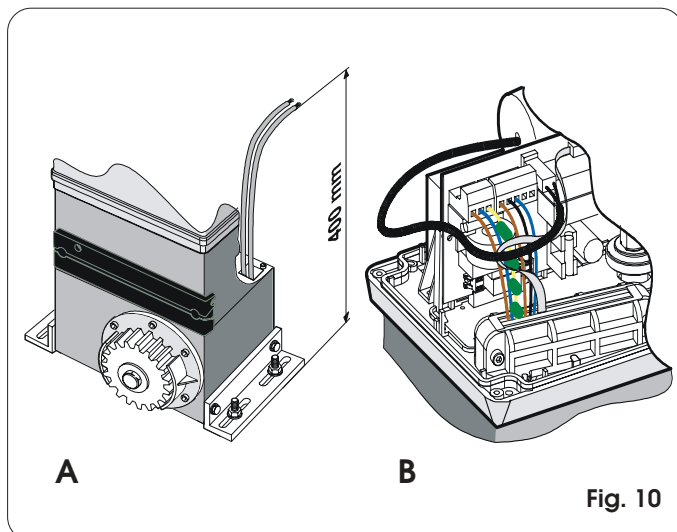

Fig. 10

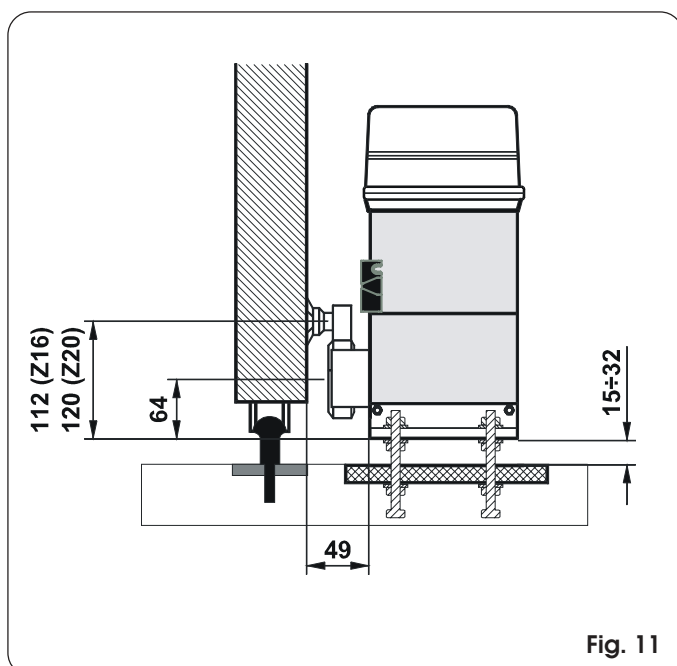

Fig. 11

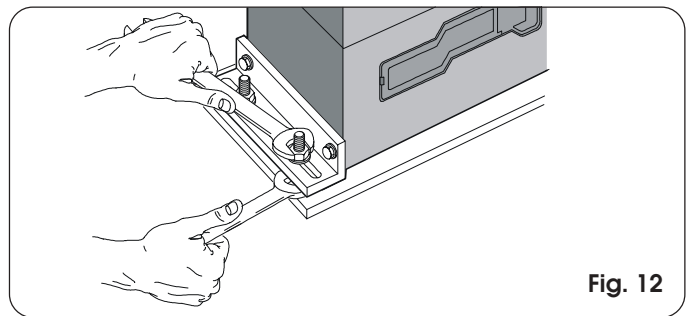

Fig. 12

4.4. INSTALLING THE RACK

4.4.1. STEEL RACK TO WELD (Fig. 13)

- 1) Place the three threaded pawls on the rack element, positioning them at the top of the slot. In this way, the slot play will enable any adjustments to be made.
- 2) Manually take the leaf into its closing position.
- 3) Lay the first piece of rack level on the pinion and weld the threaded pawl on the gate as shown in figure 15.
- 4) Move the gate manually, checking if the rack is resting on the pinion, and weld the second and third pawl.
- 5) Bring another rack element near to the previous one, using a piece of rack (as shown in figure 16) to synchronise the teeth of the two elements.
- 6) Move the gate manually and weld the three threaded pawls, thus proceeding until the gate is fully covered.

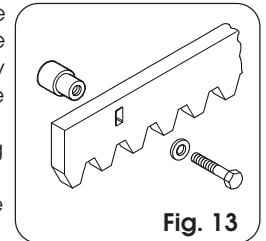

Fig. 13

4.4.2. STEEL RACK TO SCREW (Fig. 14)

- 1) Manually take the leaf into its closing position.
- 2) Lay the first piece of rack level on the pinion and place the spacer between the rack and the gate, positioning it at the top of the slot.
- 3) Mark the drilling point on the gate. Drill a $\varnothing 6,5$ mm hole and apply thread with a $\varnothing 8$ mm male tap. Screw the bolt.
- 4) Move the gate manually, checking if the rack is resting on the pinion, and repeat the operations at point 3.
- 5) Bring another rack element near to the previous one, using a piece of rack (as shown in figure 16) to synchronise the teeth of the two elements.
- 6) Move the gate manually and carry out the securing operations as for the first element, thus proceeding until the gate is fully covered.

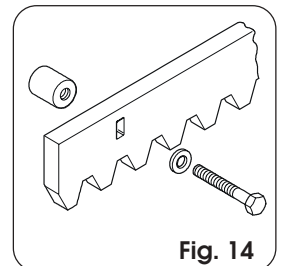

Fig. 14

4.4.3. NYLON RACK TO SCREW (Fig. 14bis)

- 1) Manually take the leaf into its closing position.
- 2) Lay the first piece of the rack level on the pinion and mark the drilling point on the gate; drill $\varnothing 4$ mm and screw the self-tapping screw 6×20 mm to the relevant reinforcing plate.
- 3) Move the gate manually, checking if the rack is resting on the pinion, and repeat the operations at point 2.
- 4) Bring another rack element near to the previous one, using a piece of rack (as shown in figure 16) to synchronise the teeth of the two elements.
- 5) Move the gate manually and carry out the securing operations as for the first element, thus proceeding until the gate is fully covered.

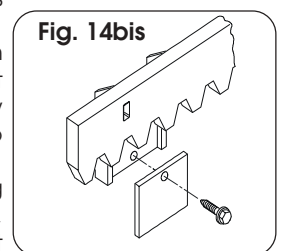

Fig. 14bis

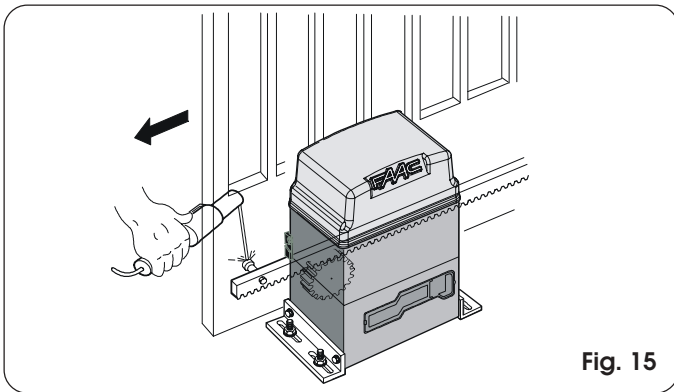

Fig. 15

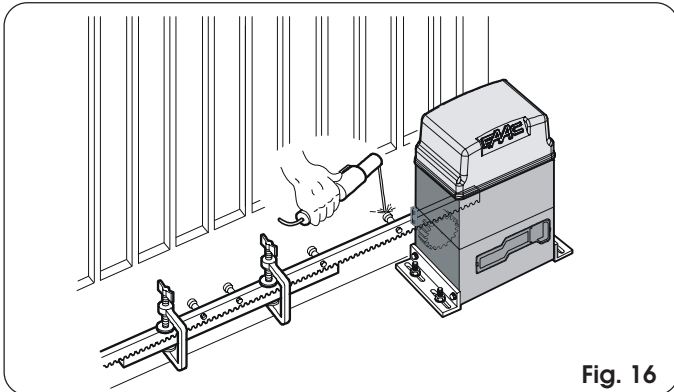

Fig. 16

Notes on rack installation

- Make sure that, during the gate travel, all the rack elements do not exit the pinion.
- Do not, on any account, weld the rack elements either to the spacers or to each other.
- When the rack has been installed, to ensure it meshes correctly with the pinion, we advise you to lower the gearmotor position by about 1.5 mm (Fig.17).
- Manually check if the gate habitually reaches the mechanical stop limits and make sure there is no friction during gate travel.
- Do not use grease or other lubricants between rack and pinion.

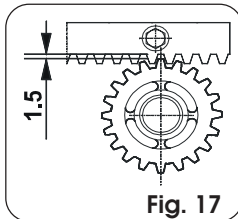

Fig. 17

4.5. INSTALLATION OF CHAIN PINIONS

In the versions for applications with chain and idle transmissions, a Z16 or Z20 chain pinion must be installed. Proceed as follows:

4.5.1. MOD. 746 ER CAT (Figs. 18 - 19)

- 1) Insert the spring pin on the shaft, using a hammer.
- 2) Fit the chain pinion on the shaft, making the pinion seats coincide with the spring pin and tighten the screw with the appropriate washers.

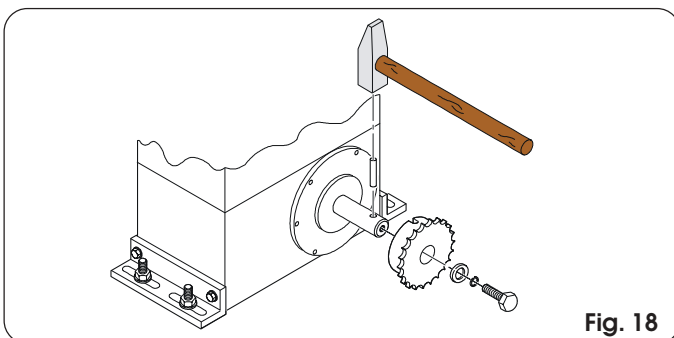

Fig. 18

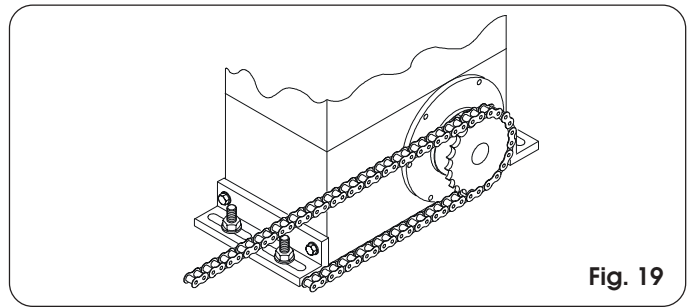

Fig. 19

4.5.2. MOD. 746 ER RF (Figs. 20 - 21)

- 1) Insert the spring pin ⑦ on the shaft, using a hammer.
- 2) Fit the idle transmissions bracket on the gearmotor flange, using the four screws ① (M5 x 12) and the appropriate washers ②, in the kit as shown in Fig. 20.
- 3) Fit the chain pinion on the shaft, making the pinion seats coincide with the spring pin and tighten the screw ④ and the appropriate washers ⑤ and ⑥.
- 4) Pass the chain as shown in Fig. 21 ref. A and install the housing with screw ① and washer ③ as in Fig. 20.
- 5) In case of operators with MLS limit switches, arrange the supports for the positioning of the magnets supplied while observing the dimensions given in fig. 21 ref. B.

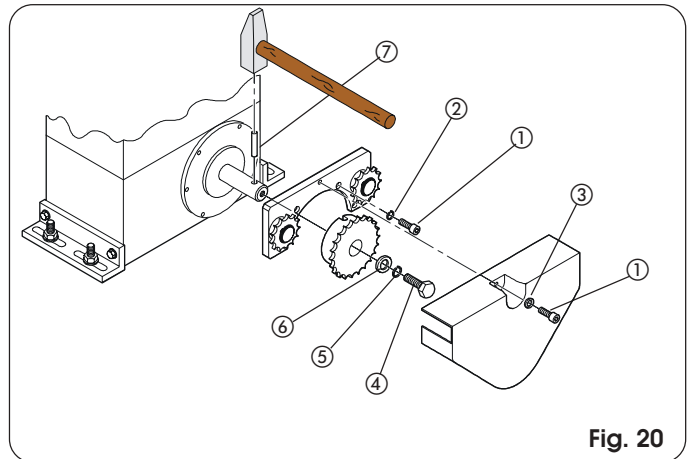

Fig. 20

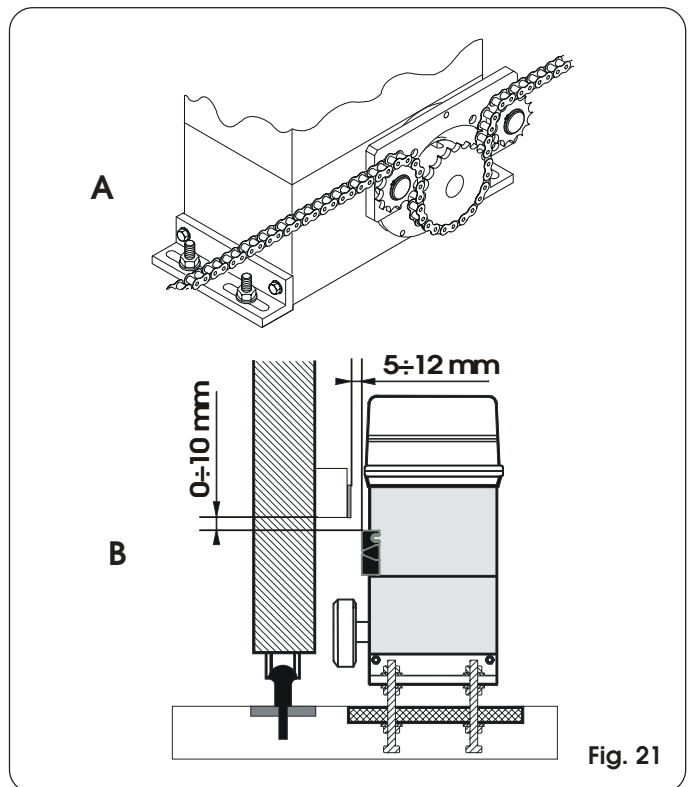

Fig. 21

5. CONTROL BOARD 780D

5.1. WARNINGS

Important: Before attempting any work on the control board (connections, maintenance), always turn off power.

- Install, upstream of the system, a differential thermal breaker with adequate tripping threshold.
- Connect the earth cable to the terminal on J7 connector of the board, and to the bush on the operator (figs. 22 and 40).
- Always separate power cables from control and safety cables (push-button, receiver, photocells, etc.). To avoid any electric noise, use separate sheaths or a shielded cable (with earthed shield).

5.2. TECHNICAL SPECIFICATIONS

Power supply V- (+6% -10%)	230
Absorbed power (W)	10
Motor max. load (W)	1000
Accessories max. load (A)	0,5
Operating ambient temperature	-20 °C +55 °C
Protection fuses	2 (see fig. 22 and par. 5.3)
Function logics:	Automatic / "Stepped" automatic / Semi-automatic / Safety devices / Semi-automatic B / Dead-man C / "Stepped" semi-automatic / Mixed B/C logic
Work time	Programmable (from 0 to 4,1 min.)
Pause time	Programmable (from 0 to 4,1 min.)
Thrust force	Adjustable over 50 levels
Terminal board inputs:	Open - Partial Open - Opening safety devices - Closing safety devices - Stop - Edge - Power supply + Earth
On-connector inputs	Opening and closing limit-switch - Motor capacitor
Terminal board outputs:	Flashing lamp - Motor - 24 Vdc accessories power supply - 24 Vdc indicator-light / Timed output / Electric lock command - 'traffic lights' - Fail safe
Rapid connector	5-pin card connection for Minidec, Decoder or RP receivers
Programming	3 keys (+, -, F) and display, "basic" or "advanced" mode
Basic mode programmable functions:	Function logic - Pause time - Thrust Force - Opening-closing direction
Advanced mode programmable functions:	Torque at initial thrust - Braking - Fail safe - Pre-flashing - Indicator-light / Timed output / Electric lock or 'traffic lights' command - Opening and closing safety devices logic - Encoder/ Anti-crushing sensitivity - Decelerations - Partial opening time - Work time - Assistance request - Cycle counter

5.3. LAYOUT AND COMPONENTS

DL	SIGNALLING AND PROGRAMMING DISPLAY
Led	INPUTS STATUS CONTROLLED
J1	LOW VOLTAGE TERMINAL BOARD
J2	CONNECTOR FOR DECODER/MINIDEC/RP RECEIVER
J5	CONNECTOR FOR MOTOR STARTING CAPACITOR
J6	MOTOR AND FLASHING LAMP CONNECTION TERMINAL BOARD
J7	230 Vac POWER SUPPLY TERMINAL BOARD
J8	DOUBLE CONNECTOR J8 - LIMIT-SWITCH QUICKFIT
F1	MOTOR AND TRANSFORMER PRIMARY WINDING FUSE (F 5A)
F2	LOW VOLTAGE AND ACCESSORIES FUSE (T 800mA)
F	"F" PROGRAMMING PUSH-BUTTON
-	"-" PROGRAMMING PUSH-BUTTON
+	"+" PROGRAMMING PUSH-BUTTON

J1 CONNECTOR

1	OPEN A (total opening)
2	OPEN B (partial opening)
3	FSW-OP (opening safety devices)
4	FSW-CL (closing safety devices)
5	STOP
6	SAFE ("edge" safety devices)
7	- (negative for power supply to accessories)
8	- (negative for power supply to accessories)
9	+24V (supply to accessories)
10	+24V (supply to accessories)
11	FSW-TX (negative for emitting photocells - FAILSAFE)
12	W.L. (negative for indicator light)

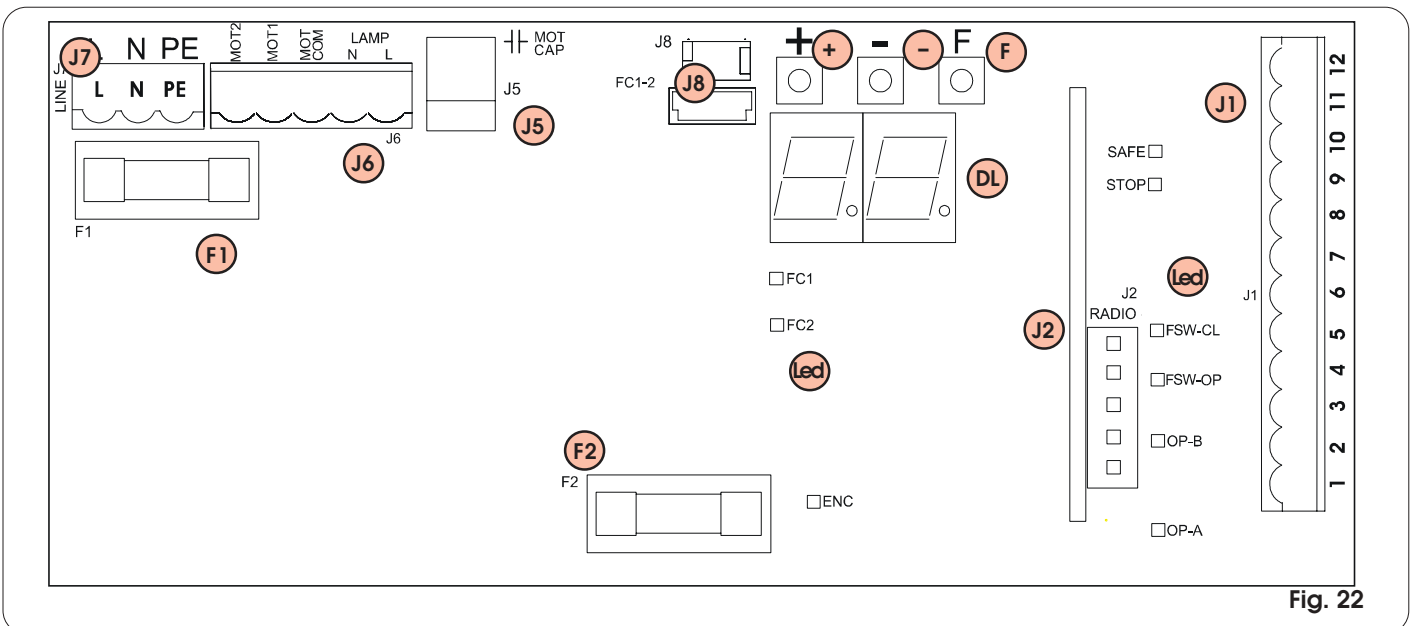

Fig. 22

5.4. ELECTRIC CONNECTIONS

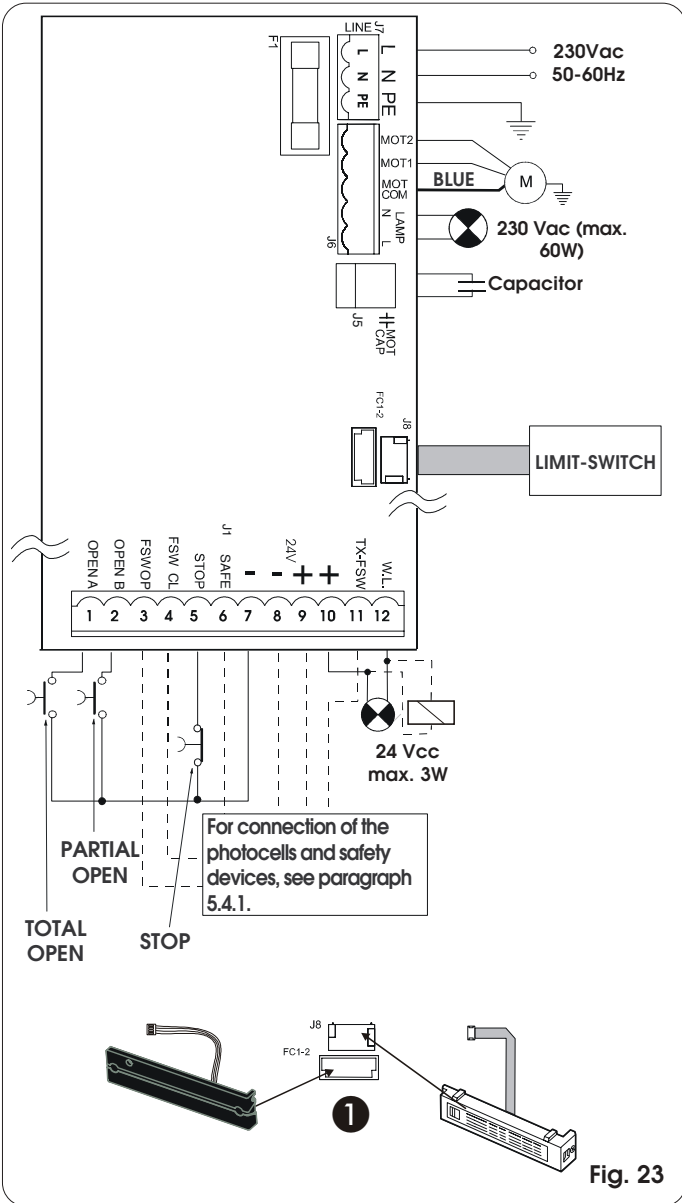

Fig. 23

5.4.1. Connection of photocells and safety devices

Before connecting the safety devices and photocells we advise you to select the type of operation according to the movement area they have to protect (see fig.24 for example):

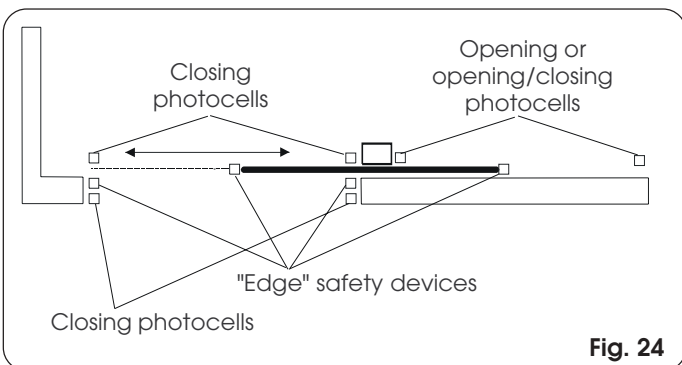

Fig. 24

Opening safety devices: they are tripped when an obstacle is detected only during gate opening movement. They cause immediate closure and resumption of opening motion on release (see programming in par. 5.5.2.)

Closing safety devices: they are tripped when an obstacle is detected only during gate closing movement. They cause re-opening, either immediate or on release (see programming in par. 5.5.2.)

Opening/closing safety devices: they are tripped during the gate opening and closing movements. They cause stopping and restart motion on release.

"Edge" safety devices: they are tripped during the gate opening and closing movements. They cause immediate reversal of motion and stopping after two seconds.

Encoder: it is tripped if there is an obstacle during gate opening and closing movements. It causes immediate reversal of motion and stopping after two seconds.

N.B. If two or more safety devices have the same function (opening, closing, opening and closing, edge), the contacts must be connected to each other in series (fig. 25).

N.C. contacts must be used.

N.B. If safety devices are not used, jumper connect the terminals as shown in fig. 26.

The most common photocell and safety device lay-outs are shown below (from fig. 27 to fig. 34).

Connection of two N.C. contacts in series (e.g. Photocells, Stop, Edge, etc.)



Fig. 25

Connection of no safety device

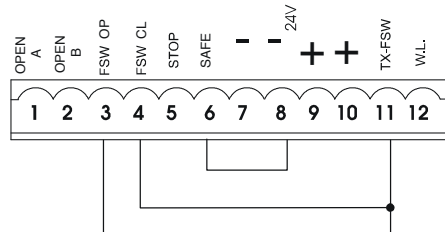

Fig. 26

Connection of a closing safety device and an opening safety device

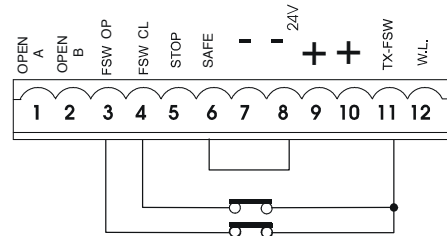

Fig. 27

Connection of an "edge" safety device

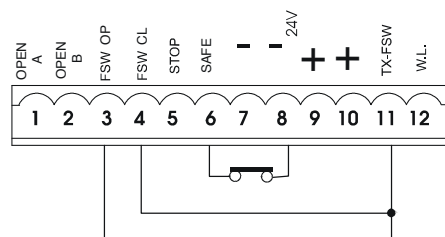

Fig. 28

Connection of a pair of opening photocells

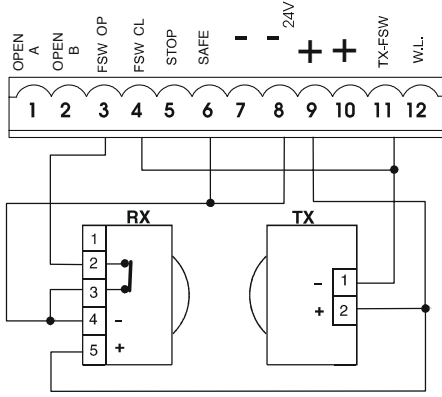

Fig. 29

Connection of a pair of closing photocells

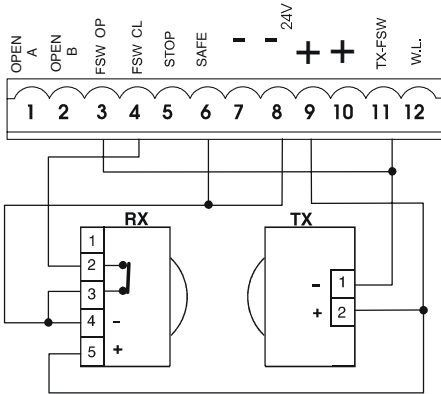

Fig. 30

Connection of a pair of opening photocells, a pair of closing photocell and an edge safety device

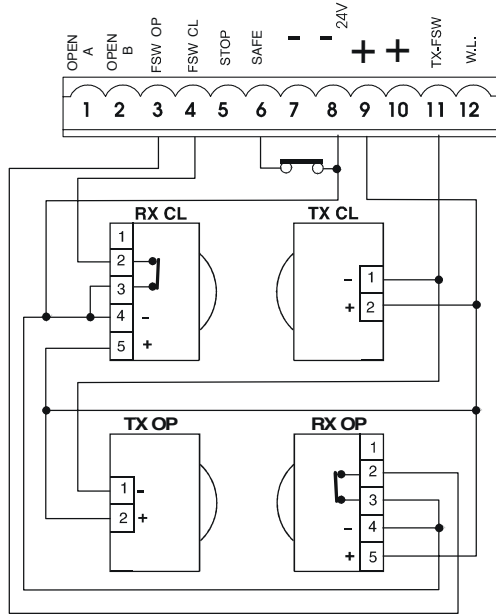

Fig. 31

Connection of two pairs of closing photocells and two edge safety devices

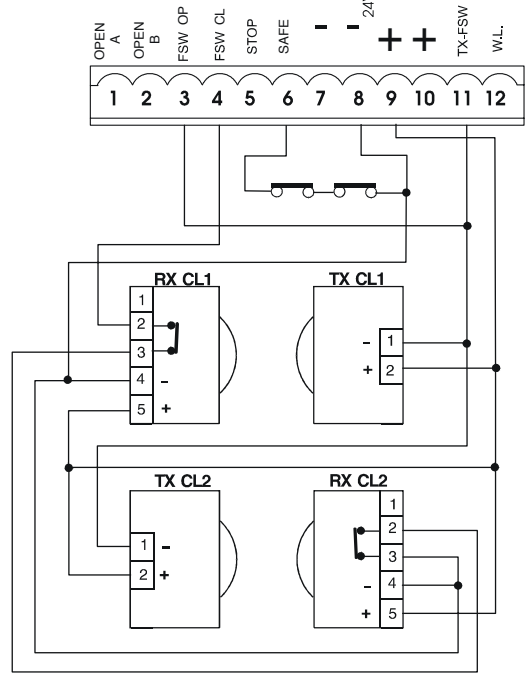

Fig. 32

Connection of a pair of closing photocells, a pair of opening photocells and a pair of opening/closing photocells

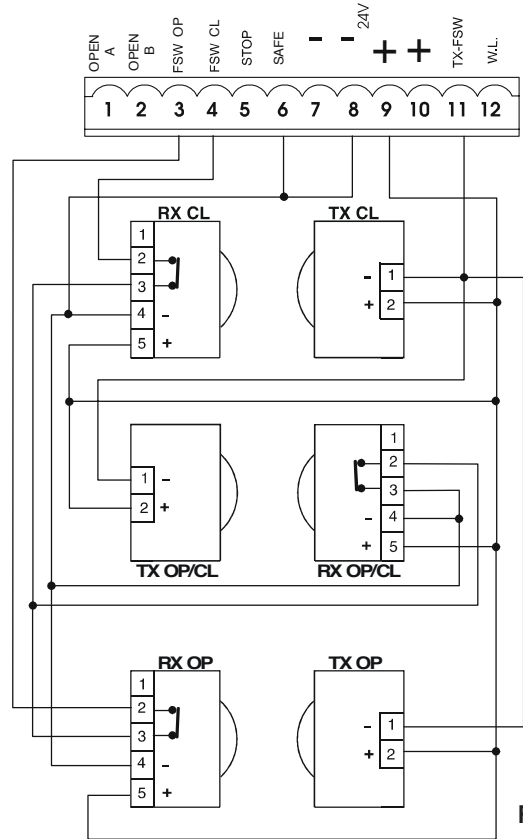
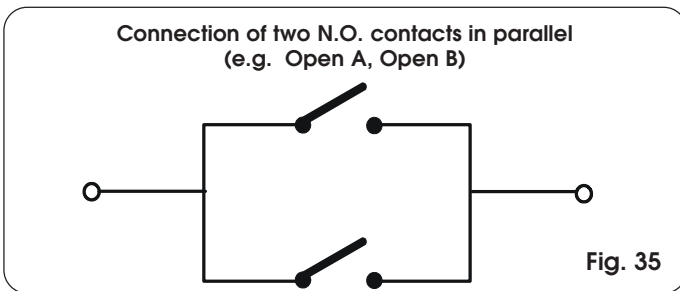
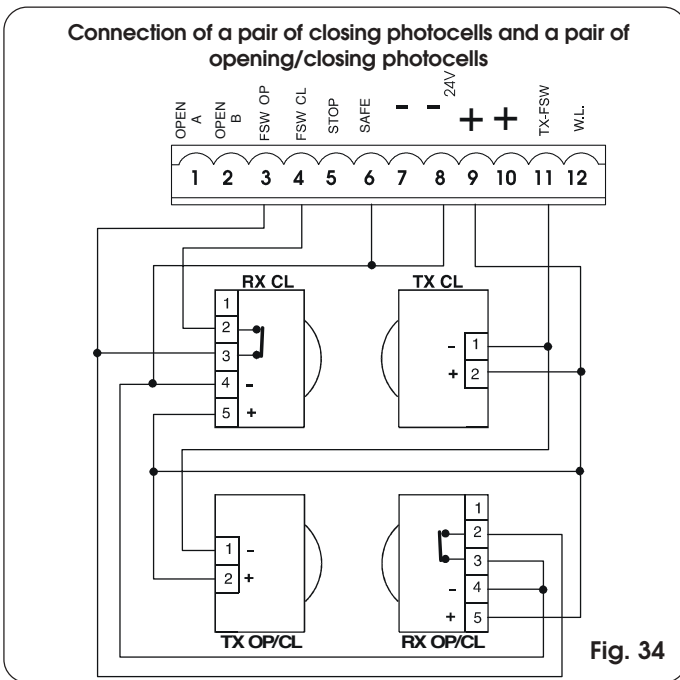

Fig. 33



5.4.2. J7 Terminal board - Power supply (fig. 23)

POWER SUPPLY (terminals PE-N-L):

- PE: Earth connection
- N : Power supply (Neutral)
- L : Power supply (Line)

NB.: For correct operation, the board must be connected to the earth conductor in the system. Install an adequate differential thermal breaker upstream of the system.

5.4.3. J6 Terminal board - Motors and flashing lamp (fig. 23)

MOTOR - (terminals MOT-C, MOT-1, MOT-2): Motor connection (see Par. 6.5).

LAMP - (terminals LAMP L, LAMP N): Flashing lamp output 230Vac max 60W.

5.4.4. J1 Terminal board - Accessories (fig. 23)

Consult the relevant tables for a detailed description of operation in the different logics

OPEN A - "Total Opening" command (terminal 1): any pulse generator (push-button, detector, etc.) which, by closing a contact, commands total opening and/or closing of the gate leaf.

To install several total opening pulse generators, connect the N.O. contacts in parallel (fig. 35).

OPEN B - "Partial opening" or "Closing" command (terminal 2): any pulse generator (push-button, detector, etc.) which, by closing a contact, commands partial opening and/or closing of the gate leaf. In the B, C and B/C logics, it always commands gate closure.

To install several partial opening pulse generators, connect the N.O. contacts in parallel (fig. 35).

FSW OP - Opening safety devices contact (terminal 3): The purpose of the opening safety devices is to protect the leaf movement area during opening. During opening, in the A-AP-S-E-EP logics the safety devices reverse the movement of the gate, or stop and restart the movement when it is released (see advanced programming in Chpt. 5.5.2). During the opening cycle in logics B, C and B/C, they interrupt movement. They never operate during the closing cycle.

If the **Opening safety devices** are engaged when the gate is closed, they prevent the opening movement.

To install several safety devices, connect the N.C. contacts in series (fig. 25).

NB.: If no opening safety devices are connected, jumper connect inputs FSW OP and -TX FSW (fig. 26).

FSW CL - Closing safety devices contact (terminal 4): The purpose of the closing safety devices is to protect the gate movement area during closing. During closing, in the A-AP-S-E-EP logics, the safety devices reverse the movement of the gate, or stop and reverse the movement when it is released (see advanced programming in Chpt. 5.5.2). During the closing cycle in logics B, C and B/C, they interrupt movement. They never operate during the opening cycle. If the **Closing safety devices** are engaged when the gate is open, they prevent the closing movement.

To install several safety devices, connect the N.C. contacts in series (fig. 25).

NB.: If no closing safety devices are connected, jumper connect terminals FSW CL and -TX FSW (fig. 26).

STOP - STOP contact (terminal 5): any device (e.g. a push-button) which, by opening a contact, stops gate movement. To install several STOP devices, connect the N.C. contacts in series (fig. 25).

NB.: If STOP devices are not connected, jumper connect the STOP and - terminals.

SAFE - EDGE safety device contact (terminal 6): The purpose of the "edge" safety device is to protect the leaf movement area during opening/closing. In all logics, during opening and closing, the safety device reverses gate movement for 2 seconds. If the safety devices operate again during the 2-seconds reversing time, it stops movement (STOP) without any reversing. If the **Edge safety device** is engaged while the gate is closed or open, it prevents movement.

To install several safety devices, connect the N.C. contacts in series (fig. 25).

NB.: If edge safety devices are not connected, jumper connect the SAFE and - inputs (fig. 26).

- **Negative for power supply to accessories (terminals 7 and 8)**
- + **24 Vdc - Positive for power supply to accessories (terminals 9 and 10)**

Important: Accessories max. load is 500 mA. To calculate absorption values, refer to the instructions for individual accessories.

TX -FSW - Negative for power supply to photocell transmitters (terminal 11)

If you use this terminal for connecting the negative for supplying power to the photocell transmitters, you may, if necessary, also use the FAIL SAFE function (see advanced programming in Chpt. 5.5.2).
If this function is enabled, the equipment checks operation of the photocells before every opening or closing cycle.

W.L. - Power supply to indicator light / timed exit / electric lock / 'traffic lights' (terminal 12)

Connect any 24 Vdc - 3 W max indicator light, timed exit, command device for electric lock or 'traffic lights' between this terminal and the +24V (see advanced programming in Chap. 5.5.2). To avoid jeopardising correct operation of the system, **do not exceed** the indicated power.

5.4.5. J2 Connector - Rapid connection to Minidec, Decoder and RP

This is used for rapid connection of Minidec, Decoder and RP receivers (see fig. 36, 37 and 38). Fit the accessory with the components side toward connector J1. Insert and remove after cutting power.

5.4.6. J5 Connector - Rapid connection to Capacitor

Quick-fit connector for connecting the motor starting capacitor.

5.4.7. Double connector J8 - Limit-switch quick fit

Quick-fit connector for connecting the limit-switch. For connecting both the MLS limit-switch and the inductive limit-switch (fig. 23 ref. ❶) to the equipment.

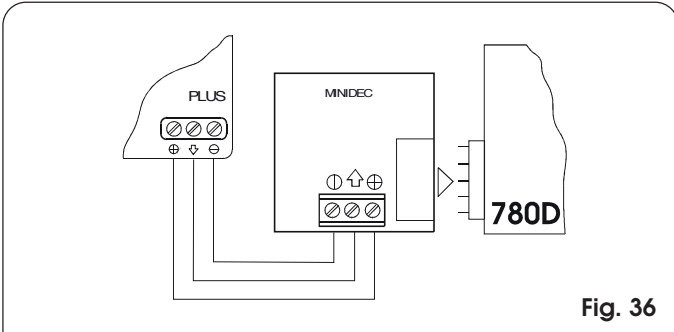

Fig. 36

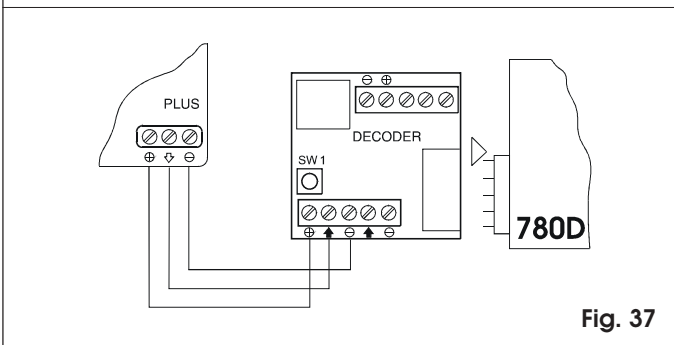

Fig. 37

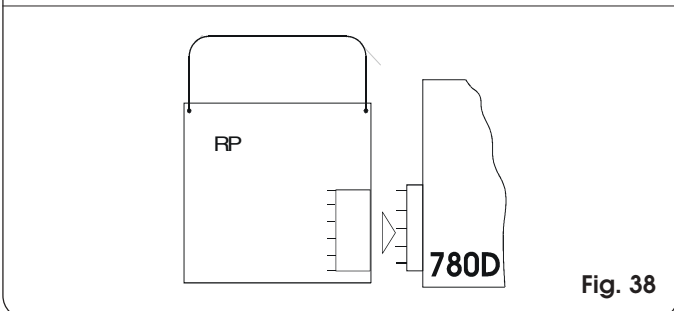

Fig. 38

5.5. PROGRAMMING

To program operation of the automated system, access the "PROGRAMMING" mode with keys F, + and -, and using the display on the equipment.

Attention: before attempting to power up the system, we advise you to re-position the equipment's cover, to avoid coming into contact with high voltage parts, and to use the push-buttons on the cover to activate the keys (fig. 39).

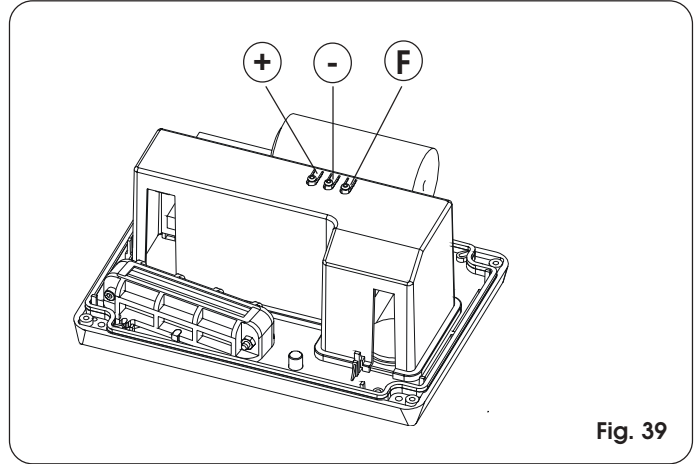

Fig. 39

Programming is divided in two parts: BASIC and ADVANCED.

5.5.1. BASIC PROGRAMMING

To access BASIC PROGRAMMING, press key F:

- if you press it (and hold it down), the display shows the name of the first function.
- if you release the key, the display shows the value of the function that can be modified with keys + and -.
- if you press F again (and hold it down), the display shows the name of the next function, etc.
- when you reach the last function, press F to exit the program, and the display resumes showing the gate status.

The following table shows the sequence of functions accessible in BASIC PROGRAMMING:

BASIC PROGRAMMING		F
Display	Function	Default
LO	FUNCTION LOGICS (see table of logics): <i>A</i> = Automatic <i>AP</i> = "Stepped" automatic <i>S</i> = "Safety" Automatic <i>E</i> = Semi-automatic <i>EP</i> = "Stepped" Semi-automatic <i>C</i> = Dead-man <i>b</i> = "B" Semi-automatic <i>bc</i> = Mixed Log. (B opening / C closing)	EP
PA	PAUSE TIME: This has effect only if the automatic logic was selected. Adjustable from 0 to 59 sec. in one-second steps. Subsequently, display changes to minutes and tens of seconds (separated by a point) and time is adjusted in 10-second steps, up to the maximum value of 4.1 minutes. E.g. if the display shows 2.5, pause time is 2 min. and 50 sec.	2.0

Display	Function	Default
F0	FORCE: Adjusts Motor thrust. 01 = minimum force 50 = maximum force	50
d1	OPENING DIRECTION: Indicates the gate opening movement and makes it possible not to change the motor connections on the terminal board. -3 = Rightward opening movement E- = Leftward opening movement	-3
St	STATUS OF AUTOMATED SYSTEM: Exit from programming, save data, and return to gate status viewing. 00 = Closed 01 = Now opening 02 = At "STOP" 03 = Open 04 = Pause 05 = "FAIL SAFE" tripped 06 = Now closing 07 = Now reversing 08 = Photocells tripped	

5.5.2. ADVANCED PROGRAMMING

To access ADVANCED PROGRAMMING, press key **F** and, as you hold it down, press key **+**:

- if you release key **+**, the display indicates the name of the first function.
- if you release key **F** too, the display shows the value of the function that can be modified with keys **+** and **-**.
- if you press key **F** (and hold it down), the display shows the name of the next function, and if you release it, the value that can be modified with keys **+** and **-** is shown.
- when you reach the last function, press **F** to exit the program, and the display resumes showing the gate status.

The following table shows the sequence of functions accessible in ADVANCED PROGRAMMING:

ADVANCED PROGRAMMING (F) (+) (+)		
Display	Function	Default
b0	MAXIMUM TORQUE AT INITIAL THRUST: The motor operate at maximum torque (ignoring the torque setting) at start of movement. Useful for heavy leaves. 4 = Active no = Disabled	4
br	FINAL BRAKING: When the gate engages the opening or closing limit-switch, a braking stroke can be selected to ensure the leaf is stopped immediately. If decelerations are selected, braking starts when they finish. At 00 value, braking is disabled. Time can be adjusted from 01 to 20 in 0,01-second steps. 00 = Braking disabled from 01 to 20 = Timed braking	05

Display	Function	Default
F5	FAIL SAFE: If this function is activated, it enables a function test of the photocells before any gate movement. If the test fails (photocells not serviceable signalled by value 05 on the display), the gate does not start moving. 4 = Active no = Disabled	no
PF	PRE-FLASHING (5s): Activates the flashing lamp for 5 seconds before start of movement. no = Disabled oP = Only before opening CL = Only before closing OC = Before every movement	no
SP	INDICATOR-LIGHT: If 00 is selected, the output functions as a standard indicator-light (lighted at opening and pause, flashing at closing, and off when gate closed). Courtesy light: Different figures correspond to timed activation of the output, which can be used (by a relay) to power a courtesy lamp. Time can be adjusted from 0 to 59 sec. in 1-second steps, and from 10 to 41 min. in 10-second steps. Electric lock command and 'traffic lights' functions: If you press key - from the 00 setting, the command for the E1 closing electric lock is activated; If you press - again, the command for the E2 closing and opening electric lock is set; if you press the - key again, you can set the 'traffic lights' functions E3 and E4. 00 = Standard indicator-light from 01 to 41 = Timed output. E1 = electric lock command before opening movement E2 = electric lock command before opening and closing movements E3 = 'traffic lights' function: the output is active in "open" and "open on pause" status and is disabled 3 seconds before the closing manoeuvre starts. Note: there is 3 seconds of pre-flashing before the closing manoeuvre. E4 = 'traffic lights' function: the output is active only in "closed" status. Attention: do not exceed the output's maximum load (24Vdc-3W). If necessary, use a relay and a power supply source outside the equipment.	00
Ph	CLOSING PHOTOCELLS LOGIC: Select the tripping mode of the closing photocells. They operate for the closing movement only: they stop movement and reverse it when they are released, or they reverse it immediately. 4 = Reverse on release no = Reverse immediately to opening	no

Display	Function	Default
OP	<p>OPENING PHOTOCELLS LOGIC: Select the tripping mode of the opening photocells. They operate for the opening movement only: they stop the movement and restart it when they are released, or they reverse it immediately. 4 = Reverse immediately to closing no = Restart movement on release</p>	no
EC	<p>ENCODER: If the encoder is used, you may select its presence. If the encoder is present and enabled, "decelerations" and "partial opening" are controlled by the encoder (see relevant paragraphs). The encoder operates as an anti-crushing device: If the gate strikes an obstacle during opening or closing, the encoder immediately reverses gate leaf movement for 2 seconds. If the encoder operates again during the 2-seconds reversing time, it stops movement (STOP) without commanding any reversing. If no sensor is supplied, the parameter must be set on 00. If there is the encoder, adjust the sensitivity of the anti-crushing system, by varying the parameter between 01 (maximum sensitivity) and 99 (minimum sensitivity). from 01 to 99 = Encoder active and sensitivity adjustment 00 = Encoder disabled</p>	99
PF	<p>Pre-limit switch DECELERATION: You can select gate deceleration before the opening and closing limit-switches have been tripped. Time can be adjusted from 00 to 99 in 0.1-second steps. If an encoder is used, the adjustment is not determined by time but by motor revs, thus obtaining greater deceleration precision. 00 = Deceleration disabled from 01 to 99 = Deceleration enabled</p>	00
PA	<p>Post-limit switch DECELERATION: You can select gate deceleration after the opening and closing limit-switches have been tripped. Time can be adjusted from 00 to 20 in 0.1-second steps. If an encoder is used, the adjustment is not determined by time but by motor revs, thus obtaining greater deceleration precision. 00 = Deceleration disabled from 01 to 20 = Deceleration enabled</p>	00

Display	Function	Default
PO	<p>PARTIAL OPENING: You can adjust the width of partial leaf opening. Time can be adjusted from 01 to 20 in 1 second steps. If an encoder is used, the adjustment is not determined by time but by motor revs, thus obtaining greater partial-opening precision. For example, with pinion Z20, partial opening can vary from about 60 cm to 4 m.</p>	05
ET	<p>WORK TIME (time-out): We advise you to set a value of 5 to 10 seconds over the time taken by the gate to travel from the closing limit-switch to the opening limit-switch and vice versa. Adjustable from 0 to 59 sec. in one-second steps. Subsequently, display changes to minutes and tens of seconds (separated by a point) and time is adjusted in 10 second steps, up to a maximum value of 4.1 minutes. Attention: the set value does not exactly match the motor's maximum operating time, because the latter is modified according to the performed deceleration spaces.</p>	4.1
AS	<p>ASSISTANCE REQUEST (combined with next function): If activated, at the end of countdown (settable with the next function i.e. "Cycle programming") it effects 2 sec. (in addition to the value already set with the PF function) of pre-flashing at every Open pulse (job request). Can be useful for setting scheduled maintenance jobs. 4 = Active no = Disabled</p>	no
NC	<p>CYCLE PROGRAMMING: For setting countdown of system operation cycles. Settable (in thousands) from 00 to 99 thousand cycles. The displayed value is updated as cycles proceed. This function can be used to check use of the board or to exploit the "Assistance request".</p>	00
SE	<p>GATE STATUS: Exit from programming, data saving, and return to viewing gate status (see par. 5.5.1.).</p>	

Note 1: to reset the programming default settings, check if the edge input is closed (SAFE LED ON), and simultaneously press keys +, - and F, holding them down for 5 seconds.

Note 2: modification of programming parameters comes into effect immediately, whereas definitive memory storage occurs only when you exit programming and return to gate status viewing. If the equipment is powered down before return to status viewing, all modifications will be lost.

6. START-UP

6.1. ELECTRIC CONNECTIONS

Make all electrical connections to the board as in chapter 5, including earthing of the operator (Fig. 40).

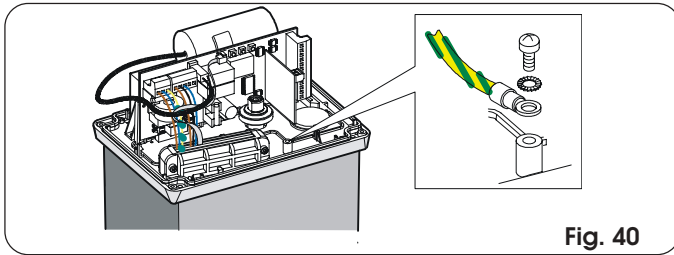

Fig. 40

6.2. DEFINITION OF OPENING DIRECTION AND OPERATION OF LIMIT-SWITCH LEADS

Power up the system and set the opening direction on the board (see par. 5.5.1).

If opening direction is **RIGHTWARD** (- \rightarrow):

- OPENING limit-switch LED = **FC1**
- CLOSING limit-switch LED = **FC2**

If opening direction is **LEFTWARD** (\leftarrow E -):

- OPENING limit-switch LED = **FC2**
- CLOSING limit-switch LED = **FC1**

6.3. DETERMINING THE STOP POINTS AT TRAVEL LIMIT

Operator 746 has a limit sensor switch which, by detecting the transit of a reference applied to the rack, commands the gate motor to stop. The device can be MLS (fig. 41) or inductive (fig. 42).

6.3.1. MLS limit-switch

The MLS limit sensor switch detects the transit of two magnets fitted on the side of the rack facing the operator.

Procedure for correct positioning of the two supplied magnets:

- 1) Check if the operator is in manual mode (see chapter 8).
- 2) Manually take the gate to opening position, leaving 2 - 5 cm from the travel limit mechanical stop.
- 3) Fit the magnet (without removing the protective film from the adhesive side) on the side of the rack facing the operator, aligning the upper edges. Slide the magnet on the rack in opening direction until the relevant LED goes off (Fig. 22 and 41), then move the magnet forward a further 45 mm.
- 4) Manually take the gate to closing position, leaving 2 - 5 cm from the travel limit mechanical stop.
- 5) Fit the magnet (without removing the protective film from the adhesive side) on the side of the rack facing the operator, aligning the upper edges. Slide the magnet on the rack in closing direction until the relevant LED goes off (Fig. 22 and 41), then move the magnet forward by about a further 45 mm.
- 6) Take the gate to its halfway travel point and relock the system (see chapter 9).
- 7) Find out the desired pre- and post-limit-switch deceleration values (see parag. 5.5.2) and run the automated system for at least one complete cycle.
- 8) Check if the gate stops at about 2 - 5 cm from its mechanical stop point. If necessary, correct the position of the magnets and check if the stop point is correct.
- 9) Mark the position of the magnets on the rack, and remove them.
- 10) Clean the rack on its fitting points, remove the film on the adhesive parts of the magnets (fig. 41 ref. 1) and re-position the magnets with the adhesive strip in contact with the rack (fig. 41 ref. 2).

Attention: due to the powerful magnetic fields the supplied magnets produce, the magnets can damage magnetic band components (credit cards, magnetic tapes, floppy disks, etc) and electronic and mechanical equipment (e.g. watches, LCD screens). We advise you not to bring them near to objects that could be damaged if 'immersed' in a magnetic field.

Notes on magnet positioning

- To ensure correct operation, allow at least 2 cm from the mechanical stop limit in the gate stop position. Carry out this check after determining the values of the pre- and post-limit switch decelerations (see par. 5.5.2.) and after running at least one complete cycle of the automated system.
 - The distance between the limit-switch and magnets must be from 5 to 12 mm.
 - Magnets should be fitted on the rack and not on the fixing screws.
- If necessary, position the magnet at the side of the screw and adjust decelerations (parag. 5.5.2) in order to obtain the correct stop point.

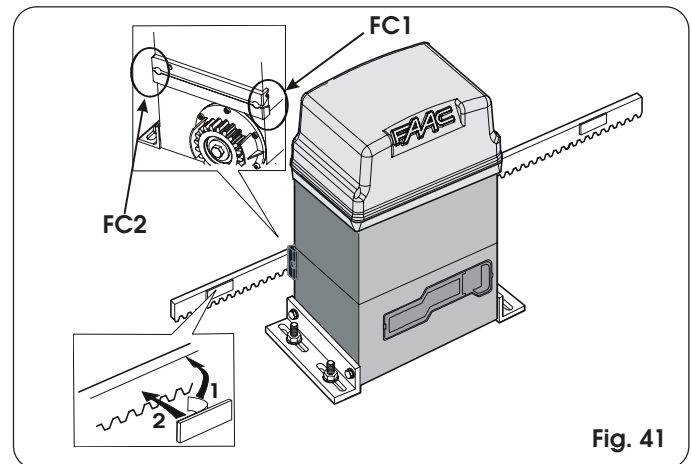

Fig. 41

6.3.2. Inductive limit-switch

Operator 746 has an inductive limit-switch which detects the transit of the two steel plates fitted on the top of the rack.

Procedure for correct positioning of the two supplied steel plates:

- 1) Assemble the limit-switch by centring the plate with respect to threaded pins of the support (Fig. 42).
- 2) Check if the operator is in manual operating mode (see chapter 8).
- 3) Manually move the gate to opening position, allowing 2 - 5 cm from the mechanical stop limit.
- 4) Allow the plate to move on the rack in opening direction until the relevant LED goes OFF (Figs. 22 and 42); next, move the plate forward by about another 45 mm and secure it to the rack by tightening the screws.
- 5) Manually move the gate to closing position, allowing 2 - 5 cm from the mechanical stop limit.
- 6) Allow the plate to move on the rack in closing direction until the relevant LED goes OFF (Figs. 22 and 42); next, move the plate forward by about another 45 mm and secure it to the rack by tightening the screws.

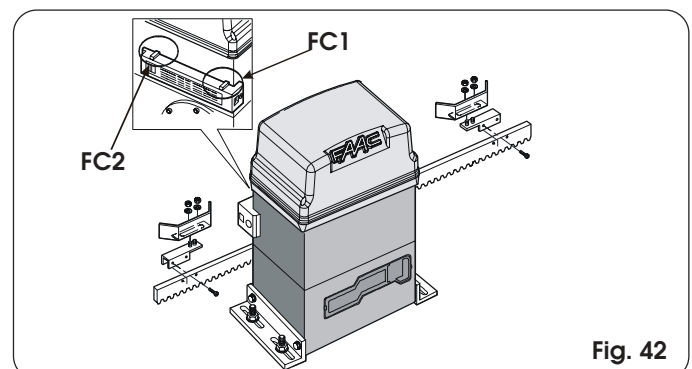

Fig. 42

Notes on plate positioning

- To ensure correct operation, allow at least 2 cm from the mechanical stop limit in the gate stop position. Carry out this check after determining the values of the pre- and post-limit switch decelerations (see par. 5.5.2.) and after running at least one complete cycle of the automated system.
- The distance between the limit-switch and the plates must be ≤ 5mm.
- For nylon racks, use the plate only (without support), securing it directly to the rack by the self-tapping screws. Make the above mentioned adjustments.

Note: a steel core is situated 5 mm under the surface of the nylon rack. Therefore, drill until you reach the steel core and screw with the self-tapping screws.

6.4. CHECK OF INPUTS

The table below shows the status of the LEDs in relation to the status of the inputs.

Note the following: **LED LIGHTED** = closed contact
LED OFF = open contact

Check the status of the LEDs as per Table.

Tab. 2 Operation of the signalling status LEDs

LEDS	LIGHTED	OFF
OP-A	Command activated	Command inactive
OP-B	Command activated	Command inactive
FC1	Limit-switch free	Limit-switch engaged
FC2	Limit-switch free	Limit-switch engaged
FSW OP	Safety devices disengaged	Safety devices engaged
FSW CL	Safety devices disengaged	Safety devices engaged
STOP	Command inactive	Command activated
SAFE	Safety devices disengaged	Safety devices engaged
ENC	Flashes while the motor rotates	

NB.: The status of the LEDs while the gate is closed at rest are shown in bold. If opening direction is leftward, the status of LEDs FC1 and FC2 is reversed.

6.5. CHECK OF MOTOR CONNECTION

Check if the motor wiring is as shown in Fig. 43 (standard connection).

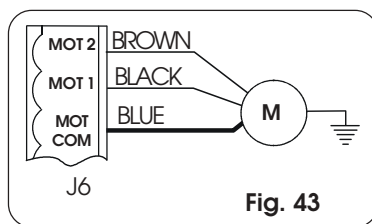

Fig. 43

6.6. ADJUSTMENT OF MECHANICAL CLUTCH

In addition to its electronic safety devices (encoder and force adjustment), the 746 operator is also equipped with a mechanical clutch.

For gate force and the encoder, please consult paragraphs 5.5.1 and 5.5.2.

Procedure for adjusting the operating threshold of the mechanical clutch (you are recommend to set it to conform with current regulations):

- 1) **Cut electrical power to the automated system.**
- 2) Keep the motor shaft locked with a wrench and turn the clutch adjustment screw with an Allen wrench or screwdriver as shown in Fig. 44.

To increase torque, turn the screw clockwise.

To reduce torque, turn the screw anti-clockwise.

➡ **The operator is supplied with the clutch set to maximum level. Therefore, you must initially turn the screw anti-clockwise to reach the best setting.**

- 3) Power up the automated system and check that the torque you have just set is correct.

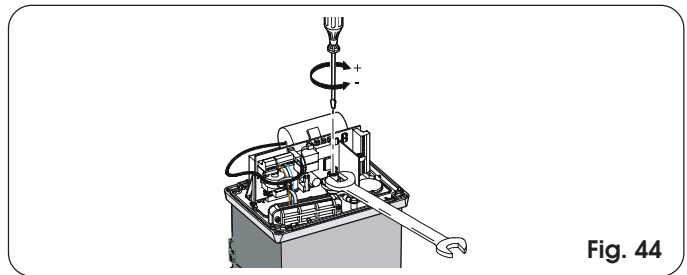

Fig. 44

6.7. CHECK OF STOP POINTS

Take care over the setting of the post-limit-switch deceleration and braking; If deceleration is too long and braking is insufficient, the reference fitted on the gate's rack (magnet or steel plate) can overtake the sensor until the latter is disengaged. When the gate stops, check if only the limit-switch involved is engaged. The relevant LED must be OFF - if it went OFF and then ON again, or if both the limit-switch LEDs are OFF, you must reduce the post-limit-switch deceleration value and/or increase braking value (see par.5.5.2).

6.8. SAFETY DEVICES AND ACCESSORIES CHECK

Check correct operation of all the safety and anti-crushing devices (ENCODER sensor), and of the accessories used on the system.

7. FINAL OPERATIONS

At end of installation, apply the danger sticker on the top of the cover (Fig. 45).

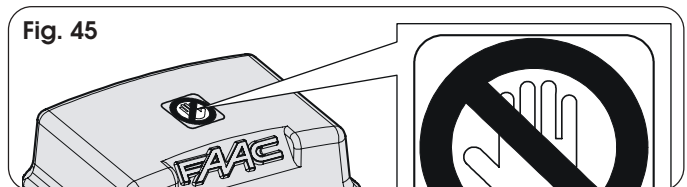

Fig. 45

Snap-fit the side panels, fit the equipment's cover and fit the cover with the supplied screws (Fig. 46).

Remove the vent stop screw (fig. 47).

Hand the "User's Guide" to the Customer, explain correct operation and use of the gearmotor, and indicate the potentially dangerous areas of the automated system.

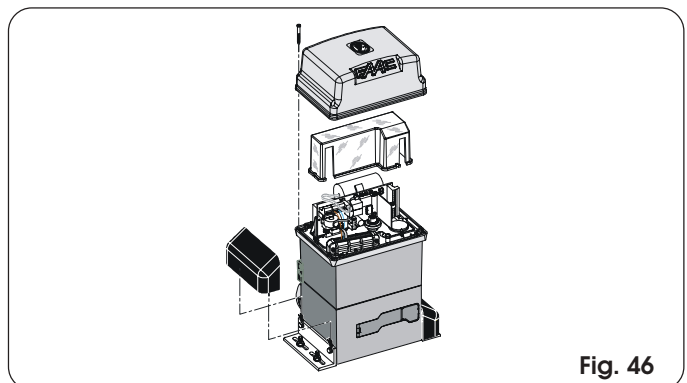

Fig. 46

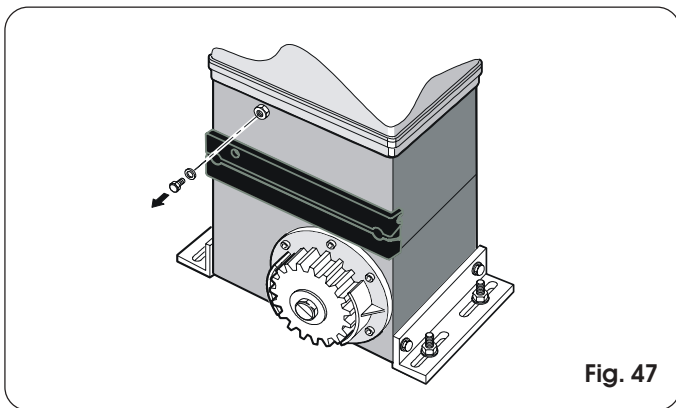

Fig. 47

8. MANUAL OPERATION

If the gate has to be operated manually due to a power cut or malfunction of the automated system, use the release device as follows:

- 1) Open the protection door and fit the supplied key in the lock (Fig. 48).

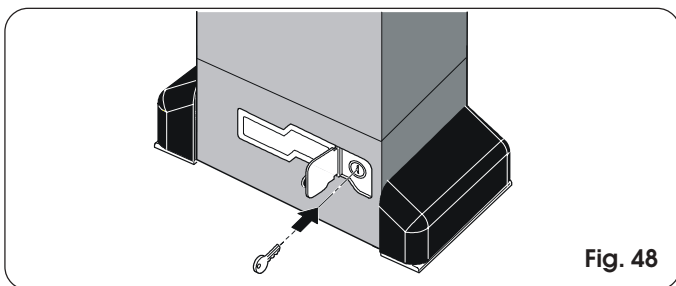

Fig. 48

- 2) Turn the key clockwise and pull the release lever as shown in Fig. 49.
- 3) Open and close the gate manually.

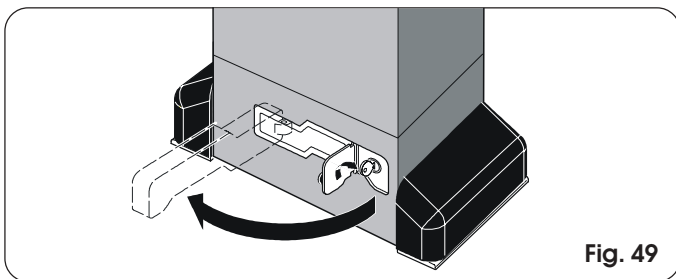

Fig. 49

9. RESTORING NORMAL OPERATION

To prevent an involuntary pulse from activating the gate during the manoeuvre, cut power to the system before re-locking the operator.

- 1) Re-close the release lever.
- 2) Turn the key anti-clockwise
- 3) Remove the key and close the lock protection door.
- 4) Move the gate until the release meshes.

10. INSTALLING THE CN 60E CONTROL UNIT (OPTIONAL)

The operator is designed to house (with the aid of a DIN bar) the CN 60E control unit of the safety conductive edge. Cut the DIN bar to measure and secure it to the operator with two screws in the appropriate holes and attach the CN 60E control unit to it (Fig. 50).

For connection and operation, refer to the specific instructions.

11. SPECIAL APPLICATIONS

There are no special applications.

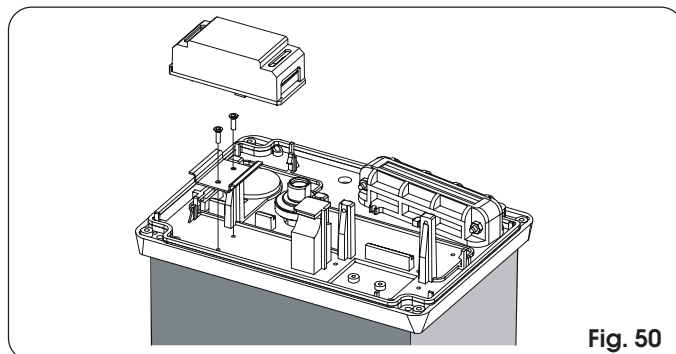

Fig. 50

12. MAINTENANCE

Check the operational efficiency of the system at least once every 6 months, especially as regards the efficiency of the safety and release devices (including operator thrust force).

12.1. DISASSEMBLING THE TRANSFORMER-BOARD UNIT

If you have to disassemble the transformer-board unit, proceed as follows:

Remove all terminal boards and connectors from the board. Unscrew the 3 securing screws of the board and the 2 of the transformer. Lift the unit up and gently remove the transformer from the couplings on the board as shown in Fig. 51.

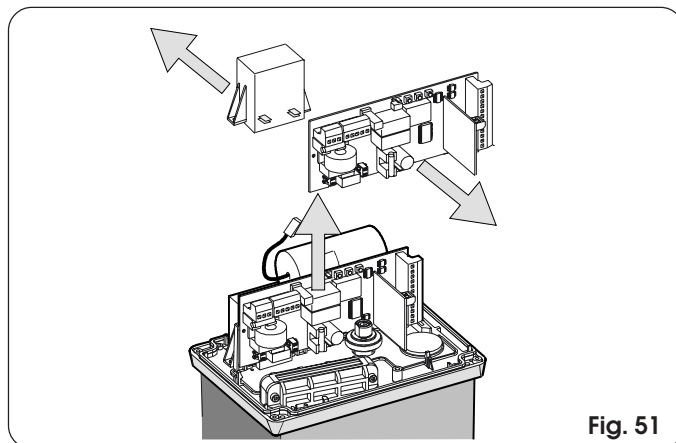

Fig. 51

12.2. OIL TOP-UPS

Periodically check oil level inside the operator. A once-a-year check is enough for medium or low use frequency. For heavier duty, every 6 months is recommended. To access the tank, temporarily remove the oil filling plug (Fig. 52).

Oil level (visually checked) must be in line with the copper windings of the electric motor.

To top up, pour in oil up to the required level.

Use FAAC XD 220 oil only.

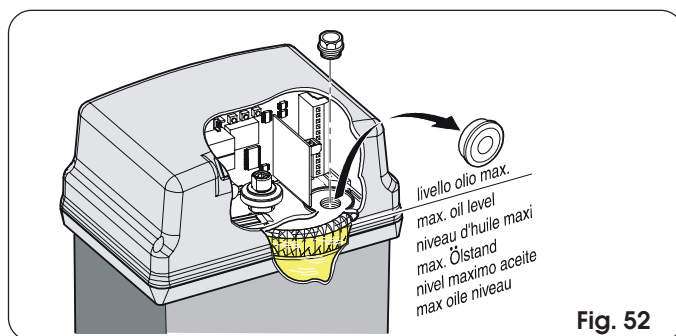

Fig. 52

13. REPAIRS

For any repairs, contact the FAAC authorised Repair Centres.

Tab. 3/a

PULSES						
Logic "A"	OPEN-A	OPEN-B	STOP	OPENING SAFETY DEVICES	CLOSING SAFETY DEVICES	EDGE SAFETY DEVICE
GATE STATUS						
CLOSED	Opens the leaf and closes it after pause time (1)	Opens leaf for the partial opening time and closes after pause time (1)		No effect (OPEN disabled)	No effect	No effect (OPEN disabled)
OPEN on PAUSE	Reloads pause time (1)(3)			No effect (if on part.opng. OPEN A disabled)	Reloads pause time (1) (3)	Reloads pause time (1) (OPEN disabled)
CLOSING	Re-opens the leaf immediately (1)		Stops operation	No effect (saves OPEN)	see paragraph 5.5.2.	Reverses to open for 2" (2)
OPENING	No effect (1) (3)			see paragraph 5.5.2.	No effect	Reverses to close for 2" (2)
LOCKED	Closes the leaf (3)		No effect (OPEN disabled)	No effect	No effect	No effect (OPEN disabled)

Tab. 3/b

PULSES						
Logic "AP"	OPEN-A	OPEN-B	STOP	OPENING SAFETY DEVICES	CLOSING SAFETY DEVICES	EDGE SAFETY DEVICE
GATE STATUS						
CLOSED	Opens the leaf and closes it after pause time	Opens leaf for the partial opening time and closes after pause time		No effect (OPEN disabled)	No effect	No effect (OPEN disabled)
OPEN on PAUSE	Stops operation (3)			No effect (if on part.opng. OPEN A disabled)	Reloads pause time (3) (OPEN disabled)	Reloads pause time (OPEN disabled)
CLOSING	Re-opens the leaf immediately		Stops operation	No effect (saves OPEN)	see paragraph 5.5.2.	Reverses to open for 2" (2)
OPENING	Stops operation (3)			see paragraph 5.5.2.	No effect	Reverses to close for 2" (2)
LOCKED	Closes the leaf (with Closing Safety devices engaged, opens at the 2nd pulse) (3)		No effect (OPEN disabled)	No effect	No effect	No effect (OPEN disabled)

Tab. 3/c

PULSES						
Logic "S"	OPEN-A	OPEN-B	STOP	OPENING SAFETY DEVICES	CLOSING SAFETY DEVICES	EDGE SAFETY DEVICE
GATE STATUS						
CLOSED	Opens the leaf and closes it after pause time	Opens leaf for the partial opening time and closes after pause time		No effect (OPEN disabled)	No effect	No effect (OPEN disabled)
OPEN on PAUSE	Re-closes the leaf immediately (3)			No effect (if on part.opng. OPEN A disabled)	On release, closes after 5" (OPEN disabled) (3)	Reloads pause time (1) (OPEN disabled)
CLOSING	Re-opens the leaf immediately		Stops operation	No effect (saves OPEN)	see paragraph 5.5.2.	Reverses to open for 2" (2)
OPENING	Re-closes the leaf immediately (3)			see paragraph 5.5.2.	No effect (saves OPEN)	Reverses to close for 2" (2)
LOCKED	Closes the leaf (3)		No effect (OPEN disabled)	No effect	No effect	No effect (OPEN disabled)

Tab. 3/d

PULSES						
Logic "E"	OPEN-A	OPEN-B	STOP	OPENING SAFETY DEVICES	CLOSING SAFETY DEVICES	EDGE SAFETY DEVICE
GATE STATUS						
CLOSED	Opens the leaf	Opens leaf for the partial opening time		No effect (OPEN disabled)	No effect	No effect (OPEN disabled)
OPEN	Re-closes the leaf immediately (3)			No effect (if on part.opng. OPEN A disabled)	No effect (3) (OPEN disabled)	No effect (OPEN disabled)
CLOSING	Re-opens the leaf immediately		Stops operation	No effect (saves OPEN)	see paragraph 5.5.2.	Reverses to open for 2" (2)
OPENING	Stops operation (3)			see paragraph 5.5.2.	No effect	Reverses to close for 2" (2)
LOCKED	Closes the leaf (with Closing Safety devices engaged, opens at the 2nd pulse) (3)		No effect (OPEN disabled)	No effect	No effect	No effect (OPEN disabled)

Tab. 3/e

Logic "EP"	PULSES					
	OPEN-A	OPEN-B	STOP	OPENING SAFETY DEVICES	CLOSING SAFETY DEVICES	OP/CL SAFETY DEVICES
GATE STATUS						
CLOSED	Opens the leaf	Opens leaf for the partial opening time		No effect (OPEN disabled)	No effect	No effect (OPEN disabled)
OPEN	Re-closes the leaf immediately (3)			No effect (if on part.opng. OPEN A disabled)	No effect (OPEN disabled) (3)	No effect (OPEN disabled)
CLOSING	Stops operation	Stops operation	Stops operation	No effect (saves OPEN)	see paragraph 5.5.2.	Locks and, on release, reverses to open
OPENING	Stops operation (3)	Stops operation (3)		see paragraph 5.5.2.	No effect	Locks and, on release, continues opening
LOCKED	Restarts movement in reverse direction (3) (always closes after a Stop)		No effect (OPEN disabled)	No effect (if it must open, it disables OPEN)	No effect (if it must close, it disables OPEN)	No effect (OPEN disabled)

Tab. 3/f

Logic "C"	PULSES					
	OPEN-A (opening)	OPEN-B (closing)	STOP	OPENING SAFETY DEVICES	CLOSING SAFETY DEVICES	OP/CL SAFETY DEVICES
GATE STATUS						
CLOSED	Opens the leaf	No effect (OPEN-A disabled)		No effect (OPEN A disabled)	No effect	No effect (OPEN A disabled)
OPEN	No effect (OPEN-B disabled)	Closes the leaf	No effect (OPEN-A/B disabled)	No effect (OPEN A disabled)	No effect (OPEN B disabled)	No effect (OPEN-A/B disabled)
CLOSING	Stops operation	/	Stops operation	No effect	Stops operation (OPEN-B disabled)	Stops operation (OPEN-A/B disabled)
OPENING	/	Stops operation		Stops operation (OPEN-A disabled)	No effect	Reverses to open for 2" (2)

Tab. 3/g

Logic "B"	PULSES					
	OPEN-A (opening)	OPEN-B (closing)	STOP	OPENING SAFETY DEVICES	CLOSING SAFETY DEVICES	OP/CL SAFETY DEVICES
GATE STATUS						
CLOSED	Opens the leaf	No effect	No effect (OPEN B disabled)	No effect (OPEN A disabled)	No effect	No effect (OPEN A disabled)
OPEN	No effect	Closes the leaf		No effect	No effect (OPEN B disabled)	No effect (OPEN-A/B disabled)
CLOSING	Reverses to open	No effect	Stops operation	No effect (saves OPEN A)	Stops operation (OPEN-B disabled)	Reverses to open for 2" (2)
OPENING	No effect	No effect		Stops operation (OPEN-A disabled)	No effect	Reverses to close for 2" (2)
LOCKED	Opens the leaf	Closes the leaf	No effect (OPEN A/B disabled)	No effect (OPEN-A disabled)	No effect (OPEN B disabled)	No effect (OPEN A/B disabled)

Tab. 3/h

Logic "B/C"	PULSES					
	OPENING PULSE/CLOSING HOLD TO RUN CONTROLS	OPEN-B (closing)	STOP	OPENING SAFETY DEVICES	CLOSING SAFETY DEVICES	OP/CL SAFETY DEVICES
GATE STATUS						
CLOSED	Opens the leaf	No effect	No effect (OPEN B disabled)	No effect (OPEN A disabled)	No effect	No effect (OPEN A disabled)
OPEN	No effect	Closes the leaf		No effect	No effect (OPEN B disabled)	No effect (OPEN-A/B disabled)
CLOSING	Reverses to open	No effect	Stops operation	No effect (saves OPEN A)	Stops operation (OPEN-B disabled)	Reverses to open for 2" (2)
OPENING	No effect	No effect		Stops operation (OPEN-A disabled)	No effect	Reverses to close for 2" (2)
LOCKED	Opens the leaf	Closes the leaf	No effect (OPEN A/B disabled)	No effect (OPEN-A disabled)	No effect (OPEN B disabled)	No effect (OPEN A/B disabled)

(1) If maintained, it prolongs the pause until disabled by the command (timer function)

(2) If a new pulse occurs within 2 seconds after reversing, it immediately stops operation.

(3) During the partial opening cycle, an OPEN A pulse causes total opening.

NB.: Effects on other active pulse inputs in brackets.

USER'S GUIDE

AUTOMATED SYSTEM 746

Read the instructions carefully before using the product and keep them for future consultation.

GENERAL SAFETY REGULATIONS

If installed and used correctly, the 746 automated system will ensure a high degree of safety. Some simple rules regarding behaviour will avoid any accidental trouble:

- Do not stand near the automated system and do not allow children and other people or things to stand there, especially while it is operating.
- Keep radiocontrols or any other pulse generator well away from children to prevent the automated system from being activated involuntarily.
- Do not allow children to play with the automated system.
- Do not willingly obstruct gate movement.
- Prevent any branches or shrubs from interfering with gate movement.
- Keep illuminated signalling systems efficient and clearly visible.
- Do not attempt to activate the gate by hand unless you have released it.
- In the event of malfunctions, release the gate to allow access and wait for qualified technical personnel to do the necessary work.
- After enabling manual operating mode, switch off the power supply to the system before restoring normal operating mode.
- Do not make any alterations to the components of the automated system.
- Do not attempt any kind of repair or direct action whatsoever and contact FAAC qualified personnel only.
- Call in qualified personnel at least every 6 months to check the efficiency of the automated system, safety devices and earth connection.

DESCRIPTION

The 746 automated system is ideal for controlling vehicle access areas of medium transit frequency.

The 746 automated system for sliding gates is an electro-mechanical operator transmitting motion to the sliding gate via a rack or chain pinion appropriately coupled to the gate.

Operation of the sliding gate is controlled by an electronic control equipment housed inside the operator.

When, with the gate closed, the equipment receives an opening command by radiocontrol or from another suitable device, it activates the motor until the opening position is reached.

If automatic operating mode was set, the gate re-closes automatically after the selected pause time has elapsed.

If the semi-automatic mode was set, a second pulse must be sent to close the door again.

An opening pulse during re-closing, always causes movement to be reversed.

A stop pulse (if supplied) always stops movement.

For details on sliding gate behaviour in different function logics, consult the installation technician.

The automated systems include accessories and safety devices (photocells, edges) that prevent the gate from closing when there is an obstacle in the area they protect.

The system ensures mechanical locking when the motor is not operating and, therefore, no lock needs to be installed.

Manual opening is, therefore, only possible by using the release system.

The gearmotor is equipped with an adjustable mechanical clutch which, combined with an electronic device, offers the necessary anti-crushing safety, by guaranteeing reversal of closing motion or stopping of opening motion.

A sensor detects transit of the references fitted on the rack, which correspond to the travel limit positions.

The electronic control equipment is housed in the gearmotor.

A handy manual release makes it possible to move the gate in the event of a power cut or malfunction. The warning-light indicates that the gate is currently moving.

MANUAL OPERATION

If the gate has to be operated manually due to a power cut or malfunction of the automated system, use the release device as follows:

- 1) Open the protection door and fit the supplied key in the lock as shown in Fig. 1.
- 2) Turn the key clockwise and pull the release lever as shown in Fig. 2.
- 3) Open and close the gate manually.

RESTORING NORMAL OPERATION

To prevent an involuntary pulse from activating the gate during the manoeuvre, cut power to the system before re-locking the operator.

- 1) Re-close the release lever.
- 2) Turn the key anti-clockwise
- 3) Remove the key and close the lock protection door.
- 4) Move the gate until the release meshes.

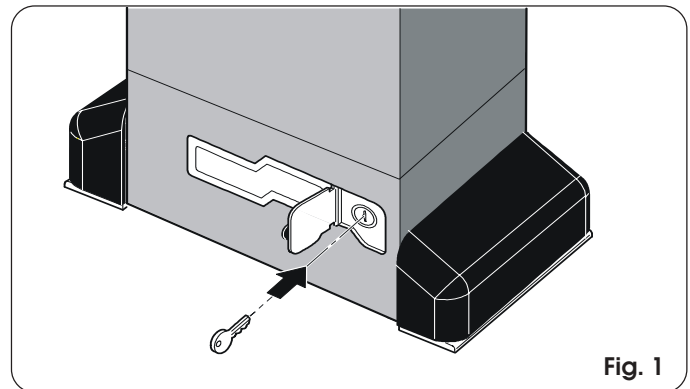

Fig. 1

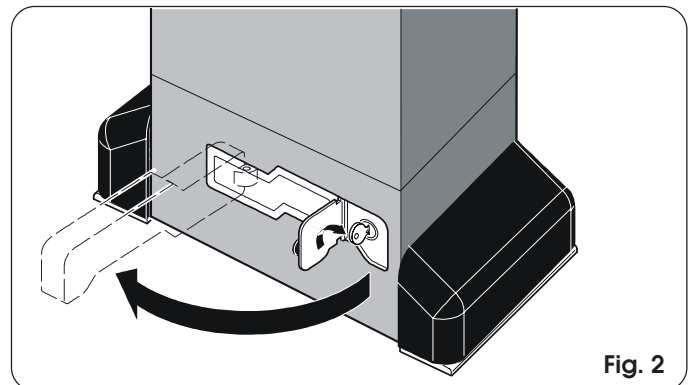

Fig. 2

Le descrizioni e le illustrazioni del presente manuale non sono impegnative. La FAAC si riserva il diritto, lasciando inalterate le caratteristiche essenziali dell'apparecchiatura, di apportare in qualunque momento e senza impegnarsi ad aggiornare la presente pubblicazione, le modifiche che essa ritiene convenienti per miglioramenti tecnici o per qualsiasi altra esigenza di carattere costruttivo o commerciale.

The descriptions and illustrations contained in the present manual are not binding. FAAC reserves the right, whilst leaving the main features of the equipments unaltered, to undertake any modifications it holds necessary for either technical or commercial reasons, at any time and without revising the present publication.

Les descriptions et les illustrations du présent manuel sont fournies à titre indicatif. FAAC se réserve le droit d'apporter à tout moment les modifications qu'elle jugera utiles sur ce produit tout en conservant les caractéristiques essentielles, sans devoir pour autant mettre à jour cette publication.

Die Beschreibungen und Abbildungen in vorliegendem Handbuch sind unverbindlich. FAAC behält sich das Recht vor, ohne die wesentlichen Eigenschaften dieses Gerätes zu verändern und ohne Verbindlichkeiten in Bezug auf die Neufassung der vorliegenden Anleitungen, technisch bzw. konstruktiv/kommerziell bedingte Verbesserungen vorzunehmen.

Las descripciones y las ilustraciones de este manual no comportan compromiso alguno. FAAC se reserva el derecho, dejando inmutadas las características esenciales de los aparatos, de aportar, en cualquier momento y sin comprometerse a poner al día la presente publicación, todas las modificaciones que considere oportunas para el perfeccionamiento técnico o para cualquier otro tipo de exigencia de carácter constructivo o comercial.

De beschrijvingen in deze handleiding zijn niet bindend. FAAC behoudt zich het recht voor op elk willekeurig moment de veranderingen aan te brengen die het bedrijf nuttig acht met het oog op technische verbeteringen of alle mogelijke andere productie- of commerciële eisen, waarbij de fundamentele eigenschappen van de apparaat gehandhaafd blijven, zonder zich daardoor te verplichten deze publicatie bij te werken.

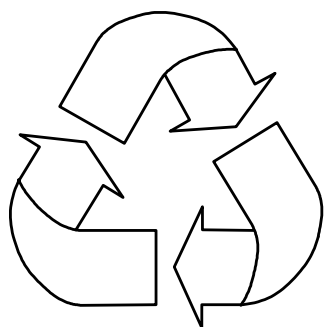

FAAC per la natura

- La presente istruzione è realizzata al 100% in carta riciclata.
- Non disperdete nell'ambiente gli imballaggi dei componenti dell'automazione bensì selezionate i vari materiali (es. cartone, polistirolo) secondo prescrizioni locali per lo smaltimento rifiuti e le norme vigenti.

FAAC for the environment

- The present manual is produced in 100% recycled paper
- Respect the environment. Dispose of each type of product packaging material (card, polystyrene) in accordance with the provisions for waste disposal as specified in the country of installation.

FAAC der Umwelt zuliebe

- Vorliegende Anleitungen sind auf 100% Altpapier gedruckt.
- Verpackungstoffe der Antriebskomponenten (z.B. Pappe, Styropor) nach den einschlägigen Normen der Abfallwirtschaft sortenrein sammeln.

FAAC écologique

- La présente notice a été réalisée 100% avec du papier recyclé.
- Ne pas jeter dans la nature les emballages des composants de l'automatisme, mais sélectionner les différents matériaux (ex.: carton, polystyrène) selon la législation locale pour l'élimination des déchets et les normes en vigueur.

FAAC por la naturaleza

- El presente manual de instrucciones se ha realizado, al 100%, en papel reciclado.
- Los materiales utilizados para el embalaje de las distintas partes del sistema automático (cartón, poliestireno) no deben tirarse al medio ambiente, sino seleccionarse conforme a las prescripciones locales y las normas vigentes para el desecho de residuos sólidos.

FAAC voor de natuur

- Deze gebruiksaanwijzing is gedrukt op 100% kringlooppapier.
- Laat de verpakkingen van de componenten van het automatische systeem niet in het milieu achter, maar scheidt de verschillende materialen (b.v. karton, polystyreen) volgens de plaatselijke voorschriften op de afvalverwerkingen en de geldende normen.

FAAC

FAAC S.p.A.
Via Benini, 1
40069 Zola Predosa (BO) - ITALIA
Tel.: 051/61724 - Fax: 051/758518
www.faacgroup.com



Timbro del Rivenditore:/Distributor's Stamp:/Timbre de l'Agent:/ Fachhändlerstempel:/Sello del Revendedor:/Stempel van de dealer:

FAAC voor de natuur 100% kringlooppapier
FAAC para la naturaleza 100% papel reciclado
FAAC ist umweltfreundlich 100% Altpapier
FAAC pour la nature papier recyclé 100%
FAAC for nature recycled paper 100%
FAAC per la natura carta riciclata 100%